



HAVELLS



**ALKALINE WATER
NATURE'S WAY**

*pH may vary depending upon input water quality, life of alkaline cartridge & RO element

Water Purifier

User Manual



UNIQUE BRASS
ROTATING FAUCET



COMPACT DESIGN
WITH INBUILT
STORAGE TANK



DOUBLE
PROTECTION



SMART
ALERTS

FAB UTC
alkaline

100% RO & UV PURIFIED ALKALINE WATER
Suitable For TDS Up to 2000 mg/L (ppm)



CONTENTS

Welcome to Havells water purifiers	4
Product overview	6
Technical specifications	7
Stages of purification	8
Water flow diagram.....	9
The purification process	10-11
Key features of Havells water purifier.....	12
Functions of smart indicators	13
Installation instructions	14
Do's, Don'ts	15
Safety instructions	16
Cleaning and maintenance	17
Recommendations and important instructions	18
Calibration & general maintenance instruction for hand held tds meter	19
How to reuse the flushed water	20
Troubleshooting	21
FAQs	22-23
Warranty terms and conditions	24-25
Havells Customer Care, Warranty Card	26-27



HAVELLS

WELCOME TO HAVELLS WATER PURIFIERS

At Havells we believe in making a difference by touching every aspect of our consumers' lives through the products we make and bringing positive changes in it. Since the very beginning all our products have been manufactured keeping the highest standards of quality and innovation in mind and we make sure that they meet the world class standards that our consumers demand. And this legacy continues unwaveringly when it comes to Havells Water Purifiers too.

Our experts with decades of experience in Water Purification Technology have been listening to the consumers and we understand that due to lack of adequate information, there are a lot of questions and confusion in the consumers' minds about the need of water purifiers today and how to choose a water purifier basis the water quality in their area. Water quality has changed drastically over the years and many water purifiers available in the market today are not effective to give protection from the new age pollutants and provide safe drinking water devoid of any impurity.

Keeping this in mind, we have designed and perfected a water purifier that recognizes the challenges of new age pollutants and removes them effectively. What makes Havells Water Purifier unique is the fact that it has a powerful purification process to remove all complex impurities, adds back wide spectrum of naturally occurring essential minerals and trace elements that were removed in the filtration process and makes it easier to absorb and hydrates your body.

It is our commitment that we continuously strive to make lives better for our consumers, so let's understand your water purifier better in the subsequent sections.

Dear Customer,

We welcome you to the ever growing family of happy Havells consumers. Havells is being trusted by millions of consumers all over the world for its quality products and efficient after sales service.

It's a matter of great pride for us that you've entrusted Havells Water Purifier for your family and home. Our experts with decades of experience in Water Purification Technology have been listening to the consumers like you and have developed this purifier keeping in mind your needs and demanding lifestyle.

We are confident that you will be satisfied with its performance and it will fulfill your need for providing clean and safe drinking water to your loved ones.

This manual is a simple and easy to understand step by step guide that explains everything you need to know about your water purifier and it will assist you to get the best performance out of it. Please go through this booklet to understand its operation and periodic maintenance.

However in case you have any query or you need further assistance, please feel free to contact us at 08045 77 1313 or e-mail us your concerns or suggestions at customercare@havells.com

We thank you again for choosing Havells Water Purifier and assure you that your journey with us will be a delightful one.

Yours sincerely

Havells India Ltd.

PRODUCT OVERVIEW – FAB UTC ALKALINE

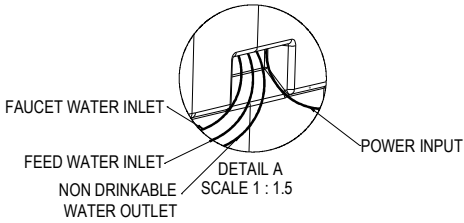
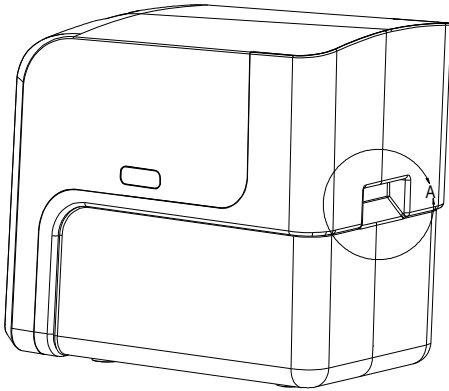
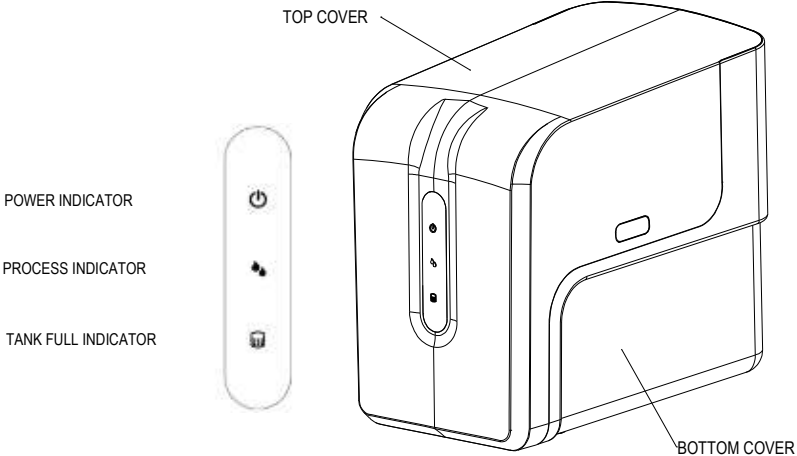

TECHNICAL SPECIFICATIONS

PARAMETERS	VALUES
Product dimensions (H x D x W) in cm	[40 (H) x 43.9 (D) x 28.6 (W)] cm
Net weight	~ 10.5 kg
Flow rate*	Up to 25 L/h
Storage Tank capacity	7 L at 0.276 MPa (40 psi)
Purification technology	Absolute safety through 100% RO & UV technology.
Purifying stages	10 STAGES
Membrane type#	Thin film composite Reverse Osmosis membrane
Material of construction for plastic components	Food grade
Power rating (maximum)	45 W
Working voltage	1 Phase, 150 V - 250 V AC, 50 Hz
% Recovery**	≥ 40%
TDS reduction**	≥ 90%
System disinfection efficacy	6, 4, 3 Log reduction of bacteria, viruses & cysts
Installation type	Floor Mounted
pH##	Purified Water pH in Alkaline range

RECOMMENDED FEED WATER QUALITY

PARAMETERS	LIMITS
Total Dissolved solids	Up to 2000 mg/L (ppm)
Total Hardness	Up to 600 mg/L (ppm)
Turbidity ***	Up to 5 NTU
Feed water Pressure****	0.041 MPa (6 psi) to 0.21 MPa (30 psi)
Feed water temperature	5 °C - 45 °C
Iron *****	Less than 0.3 mg/L
Free chlorine	Less than 0.2 mg/L

*Flow Rate may vary depending upon feed water quality, input water pressure, condition of membrane & cartridges.

** Recovery / TDS percentage reduction may vary depending upon type of feed water, feed water pressure & cartridges life.

***In case, input turbidity is more than 5 NTU, you need to install pre filter at an additional cost.

****In case, input water pressure goes below 0.041 MPa (6 psi), you need to install external booster pump and if pressure is above 0.21 MPa (30 psi), you need to install pressure reducing valve at an additional cost

*****In case, the Iron content in input water is more than 0.3 mg/L, you need to install IRON REMOVER PLUS at an additional cost.

#The chemical preservative used in the RO membrane is of food grade quality.

##Under Standard test conditions of Alkaline Cartridge (as per BIS standard IS 10500:2012)

STAGES OF PURIFICATION

FAB UTC ALKALINE

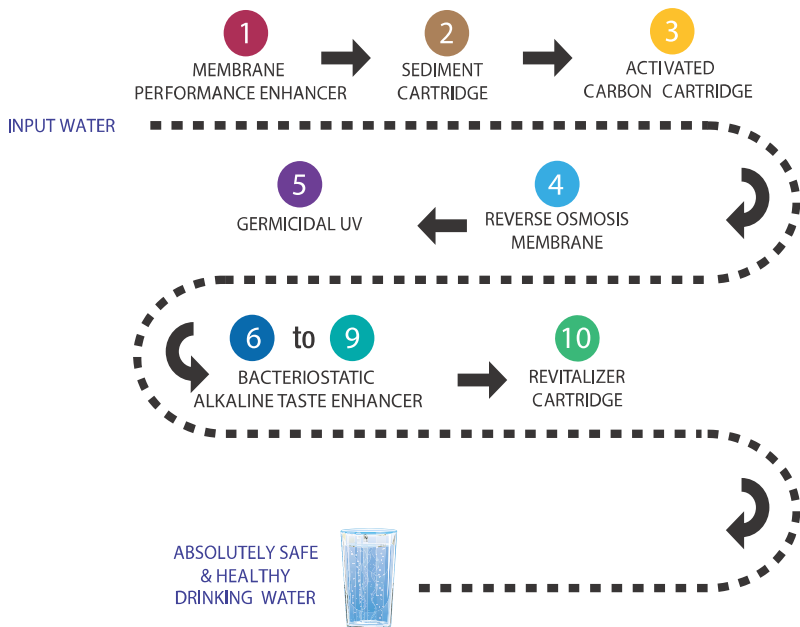

WATER FLOW DIAGRAM - FAB UTC ALKALINE

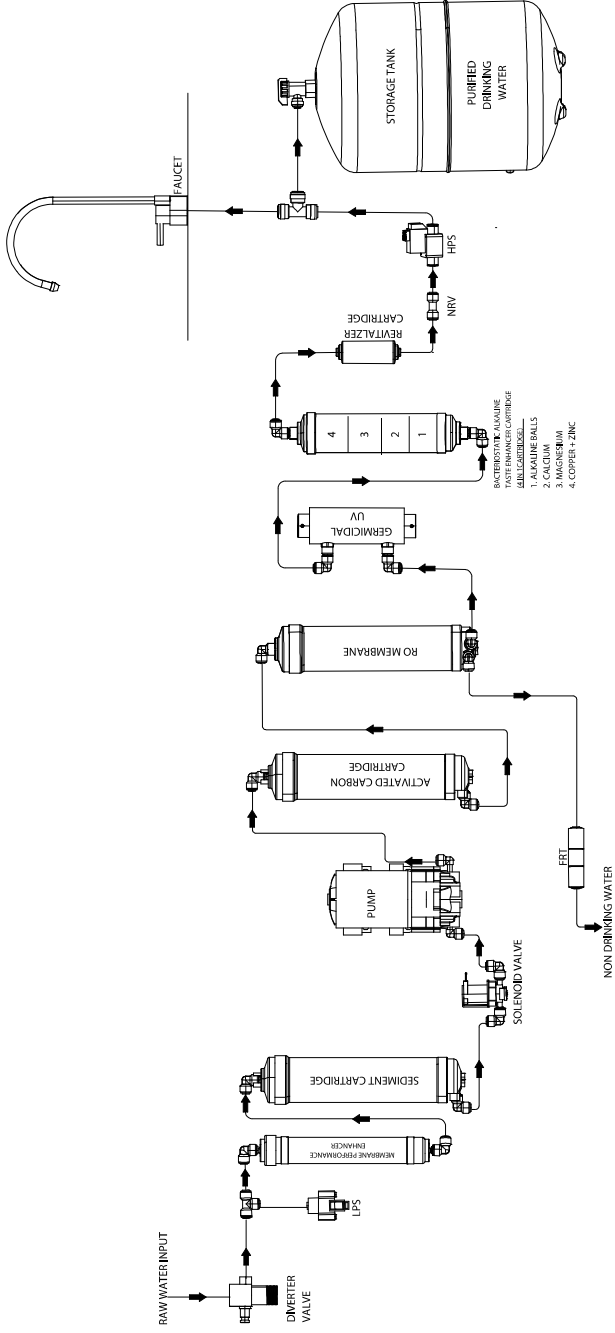

THE PURIFICATION PROCESS

Havells Water Purifiers have a powerful purification process which is divided into 3 Phases viz. Pre-Treatment, Purification & Value Additions.

In pre-treatment process water will pass through Membrane Performance Enhancer, Sediment Filter and Activated Carbon Filter-cum-adsorber.

During the purification process 100% water passes through RO Membrane followed by Germicidal UV disinfection column. In the next page stage of purification, pH of water will be balanced and minerals will be added to purified water. Zinc Impregnated Taste Enhancer will enhance the taste of purified water further.

In the final stage of purification, water will pass through a controlled bipolar magnetic field which realigns the water molecules and makes it easy to absorb and more bioavailable.

The names of all the cartridges along with their functions and benefits are explained below for better understanding.

1

MEMBRANE PERFORMANCE ENHANCER

It prevents scaling formation on RO Membrane due to hardness in feed water, which results in improved performance and enhances the life of RO membrane.

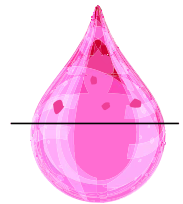

2

SEDIMENT CARTRIDGE

Sediment Cartridge removes coarse and fine suspended impurities such as sand, silt, dust, clay, rust particles etc. from the feed water. This improves the performance and the life of activated carbon cartridge and the RO membrane.

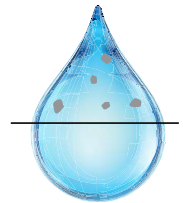

3

ACTIVATED CARBON CARTRIDGE

Activated Carbon, filter-cum-adsorber Cartridge removes a wide range of dissolved organic impurities like pesticides and herbicides along with residual chlorine and its by-products (THMs) present in the water. It also removes colour & objectionable odour from water. This in turn improves the taste of the water.

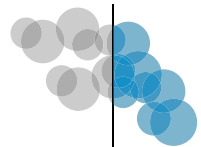

4 REVERSE OSMOSIS MEMBRANE

Reverse Osmosis Membrane removes dissolved contaminants such as dissolved solids, salinity, pesticides, herbicides as well as hazardous heavy metals like Arsenic, Chromium, Lead and Fluorides etc. It also removes harmful microbiological impurities such as bacteria, viruses and cysts from the feed water. It ensures absolutely safe and pure drinking water.



5 GERMICIDAL UV PLUS

An optimum exposure of water to germicidal UV-C radiation in UV disinfection column makes water free from microbiological threats like pathogenic bacteria & viruses.

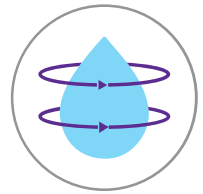

6 BACTERIOSTATIC ALKALINE & TASTE ENHANCER

to

9

It enhance the pH of purified water by adding back wide spectrum of natural minerals & trace elements such as Calcium, Magnesium, Potassium, Sodium, Copper, Zinc, etc. It lowers the Oxidation Reduction Potential (ORP) resulting into anti-oxidant nature of water, transforms regular water into Alkaline Water, It also removes organic residues and VOC, which enhances the taste of purified water and results in healthier water.



10 REVITALIZER CARTRIDGE

Revitalizer Cartridge realigns the water molecules and makes it biologically active. It improves the hydration and mineral absorption in body

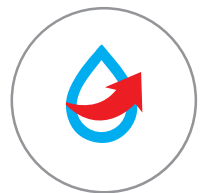

KEY FEATURES OF HAVELLS WATER PURIFIER

A. DOUBLE PROTECTION: 100 % RO + GERMICIDAL UV PURIFICATION:

Absolute Safety through 100% RO Purified Water:

100% Water passes through the RO Membrane to ensure absolutely safe and pure drinking water.

Purification through Germicidal UV LAMP:

An optimum exposure of water to UV-C radiation makes water free from microbiological threats like pathogenic bacteria & viruses.



B. BACTERIOSTATIC ALKALINE & TASTE ENHANCER CARTRIDGE:

It enhance the pH of purified water by adding back wide spectrum of natural minerals & trace elements such as Calcium, Magnesium, Potassium, Sodium, Copper, Zinc, etc. It lowers the Oxidation Reduction Potential (ORP) resulting into anti-oxidant nature of water, transforms regular water into Alkaline Water, It also removes organic residues and VOC, which enhances the taste of purified water and results in healthier water.



C. REVITALIZER CARTRIDGE:

It realigns the water molecules and makes it biologically active. It improves the hydration and mineral absorption in body



D. COMPACT DESIGN:

Easy to install & service, under the sink. Optimize the space of your modular kitchen, with inbuilt storage tank.



E. TDS REMOVAL OF UP TO 2000 mg/L (ppm):

Havells Water Purifiers work effectively in TDS of 2000 mg/L (ppm) and deliver pure and healthy water that taste good.



F. ROTATING FAUCET:

Unique brass faucet with flow control and rotates 360°



FUNCTIONS OF SMART INDICATORS

SELF-DIAGNOSTIC MODE

When machine is switched - ON all the indicators will glow for a fraction of second. Thereafter the power indicator will glow solid & same time purification process indicator will also glow solid for 30 seconds. During this period the water present in UV column will get disinfected. After 30 seconds the purification process will start & purification process indicator will blink till the tank is full.



PURIFICATION PROCESS INDICATOR

Purification process indicator blinks continuously when the purification is on. It will disappear once purification process stops.



TANK FULL INDICATOR

Tank Full Indicator glows solid when the tank is full.



ERROR INDICATIONS

In the event of failure of Pump and SV power indicator will start blinking at the rate of 1 second with buzzer sound. If UV intensity is less than adequate for disinfection of water power indicator will start blinking at the rate of 2 second with buzzer sound. System will shut off in both the cases to deliver you the promise of safe water or no water.



In case of Low pressure condition (Input water pressure is not adequate) then tank indication will blink.



INSTALLATION INSTRUCTIONS

1. Before installation, take out the following items from accessory kit for installation:
 - a) Diverter valve
 - b) Faucet box
2. Select an appropriate water connection point under the counter.
Be sure to turn off the water supply.
3. Ensure water purifier is connected to ambient temperature water supply only.
4. Fix diverter valve with the help of pipe wrench/plumbing equipment at selected water point.
5. Place the water purifier on floor, under your counter.
6. For faucet mounting:- make a hole of 1.2 cm with the help of appropriate drill bit in the counter or sink corner as per the choice. Thickness of mounting surface should not exceed 3.81 cm
7. With having appropriate length of white pipe connect the water inlet pipe from diverter valve to feed water inlet port of water purifier and open the diverter valve. Ensure there is no leakage of water and kinking of pipe at any point.
8. Insert the outlet (blue pipe) to the flushed water outlet port of water purifier.
9. For tank: cut the appropriate length of white pipe and connect the tank from the unit.
10. For faucet: similarly with appropriate pipe length connect the pipe from unit to faucet.
11. Plug the 3 pin power cord into the power socket.
12. Switch On the mains and unit will start working.
13. It is advised to drain the first fill of water tank after installation of the water purifier or after changing the filters. This water can be used for washing, cleaning and other household purpose.

CAUTION: Before installation/mounting: Flush all filters and membrane thoroughly and independently for 3 minutes- 5 minutes to remove fine particles & preservatives present in filters. Now start the machine and flush bacteriostatic alkaline taste enhancer with RO treated water. Check input water pressure. Use booster pump if feed water is less than 0.041 MPa (6 psi), or pressure reducing valve if it is more than 0.21 MPa (30 psi) which is available at an additional cost.

The appliance is intended to be permanently connected to the water mains and not connected by a hose-set.

DO'S, DON'TS & SAFETY INSTRUCTIONS

DO'S ✓

Always install the water purifier in a cool, dry and well ventilated place in upright position.

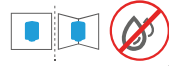

To keep your purifier functioning properly, always use Havells genuine spare parts.



Call Havells customer care for any assistance and service requirement.



Keep the purifier in power ON mode to ensure water availability at all times. System automatically shuts OFF when tank is full of purified water.



If for any reason you are not using the water purifier for a long time, for example during a holiday, then make sure that you disconnect the power supply, turn off the input water supply and drain the storage tank.



DON'TS ✗

Never connect your water purifier to hot water supply as it is designed to work effectively for input water supply between 5 °C to 45 °C temperature.



Never place any heavy, sharp or wet objects on the purifier.



In case of any break down do not buy local spares parts and components for service or replacement.



Do not install product in direct sunlight.



SAFETY INSTRUCTIONS

Havells Water Purifier is designed keeping in mind the highest safety standards, but there are certain safety precautions that need to be followed while using the product for its proper functioning.

Do not move or relocate the purifier when it is working.



To avoid electric shock, do not pull out or touch the power plug with wet hands.



Do not use the water purifier if the power cord is damaged or if there's a strange noise, burning smell or smoke. Quickly switch off the power, unplug the cord and call Havells Customer Care.



Don't open the purifier yourself to clean the cartridges or to replace any parts.



Never use the discarded water from the purifier for drinking. However it can be used for cleaning, washing, mopping, gardening etc.

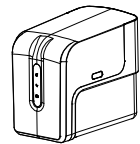

This appliance is not intended for use by persons (including children) with reduced physical, sensory or mental capabilities, or lack of experience and knowledge, unless they have been given supervision or instruction concerning use of the appliance by a person responsible for their safety.

Children should be supervised to ensure that they do not play with the appliance.

If the supply cord is damaged, it must be replaced by the manufacturer, its service agent or similarly qualified persons in order to avoid a hazard.

CLEANING AND MAINTENANCE

Use a wet cloth to clean the external body of the purifier. Do not use detergent or soap.



Avoid excessive rubbing of the decorative part of the purifier while cleaning as it may lead to scratches or loss of shine of the purifier.



Make sure you switch off the power supply and close the diverter valve whenever you're out of home for a long duration.



Do not try to open or tamper the purifier yourself if you observe any problem. Kindly contact Havells Customer Care to resolve the issue. Water purifier should be examined by Havells trained service engineer only.



Do not clean the water purifier or spill water on it, while the purification process is on.



RECOMMENDATIONS AND IMPORTANT INSTRUCTIONS

Recommended Cartridge Replacement:

Membrane Performance Enhancer Cartridge, Sediment Cartridge and Activated Carbon Cartridge need to be replaced after 1 year of installation or after dispensing 6000 litre* of purified water, whichever is earlier.



RO (Reverse Osmosis) Membrane Replacement:

As per the warranty, RO Membrane needs to be replaced after 1 year of installation or after dispensing 6000 litre* of purified water, whichever is earlier.



Bacteriostatic Alkaline Taste Enhancer Cartridge:

Bacteriostatic Alkaline taste enhancer cartridge needs to be replaced after 6 months of installation or after dispensing of 3000 L*, of water, whichever is earlier.



Germicidal UV Column:

UV lamp needs to be replaced after 5000 burning hours or based on service requirement.



Note: Please read the warranty details and their terms and conditions for replacement requirement of individual cartridges.

* May vary depending on the feed water quality.

CALIBRATION & GENERAL MAINTENANCE INSTRUCTION FOR HAND HELD TDS METER

The functioning of the TDS Meter will be ascertained by our authorized service representative periodically (at least once in 6 months, during Preventive service) or as per the customer request.

For Calibration

1. Take the 100 ml water of standard solution in a beaker.
2. Carefully immerse the probes of the TDS Meter in the standard calibration solution and turn ON the TDS meter.
3. The TDS of water will display, wait for 10 seconds - 20 seconds to stable the reading.
 - i. If value matches with the standard calibration solution ($\pm 10\%$) then calibration is considered as completed.
 - ii. If the value does not match with the standard calibration solution then follow below instructions
 - a. To adjust the readings, long press the HOLD icon for 3 seconds. Hold will starts blinking on display.
 - b. Then press the Temp. icon. TDS of the standard calibration solution will display and blinks on the display to indicate that calibration is completed.
4. Remove the TDS meter from the solution. Clean the probe by purified water and dry it with the help of cloth/cotton.
5. Turn the meter off, wait for a moment & turn ON the meter again to start using.

For General Usage & Maintenance

1. Immerse the meter in the water/solution such that the probes are completely dipped in it.
2. Shake & clean with purified water after each use.
3. The meter is not water proof. DO NOT drop or submerge the meter in water.
4. Do not store the meter in high temperature or direct sunlight.
5. Replace the battery if the display is dim or readings are consistently not accurate.

Important Notes.

1. TDS Meter Range: From 0 mg/L to 2000 mg/L.
2. Tolerance: $\pm 10\%$ of water TDS.
3. Depending on the make of the meters, the calibration buttons may be "on/off" or "hold" or a combination of both. Contact authorized Havells service technician for support.

HOW TO REUSE THE FLUSHED WATER

Although the flushed water from the purifier has slightly higher concentration of TDS and hardness, but it is filtered and activated carbon treated tap water. It is recommended to use this water for following activities:

- Can be used for watering the plants
- Can be used for mopping and cleaning the floor
- Can be used to clean bathroom



TROUBLESHOOTING

	PROBLEMS	CHECKS	SOLUTIONS
<p>Before calling customer care or service engineer, check the following points:</p> <ol style="list-style-type: none"> 1. Power supply should be ON 2. Inlet water supply should have sufficient pressure/ Waterflow 	<p>Purified Water taste is bad or unusual</p>	<ol style="list-style-type: none"> 1. Is purified water being stored in the tank for a long time? 2. Is the Cartridge replacement due as per the service requirement? 	<ol style="list-style-type: none"> 1. Discard the water stored in tank and clean the tank before starting the purification process again. 2. Contact Havells Customer Care to request for the cartridge replacement.
	<p>Purification time is very long/short or filtration has stopped/too much water is being purified.</p>	<ol style="list-style-type: none"> 1. Is the diverter valve open properly? 2. Is water pressure below recommended value? 3. One or more Cartridges may have been clogged or damaged. 	<ol style="list-style-type: none"> 1. Open the water inlet valve completely. 2. Contact Havells Customer Care to get the pressure checked and get it resolved. 3. Contact Havells Customer Care to get the cartridges replaced.
	<p>Very less or no water is being flushed out.</p>	<ol style="list-style-type: none"> 1. Check if the flushed water pipe (Blue pipe) is bent anywhere. 2. Check if the flushed water pipe is blocked in any place. 	<ol style="list-style-type: none"> 1. Remove the bend in the flush water pipe if found. 2. Switch off the purifier and contact Havells Customer Care for proper checking the product.
	<p>Water leakage in any part.</p>	<p>Check if water is dripping from purifier or connecting pipe.</p>	<p>Close the water inlet valve, unplug the power cord and then contact Havells Customer Care for a check-up of the product and get it rectified.</p>

FAQs

1. What is TDS?

TDS stands for Total Dissolved Solids in water. This affects taste of water and beverages prepared with such water.

2. Is the purification process completely automated or a manual intervention is required?

The purification process is completely automatic. Purification starts when water level in purified water tank goes down and stops once water tank is full.

3. How much time does it take to purify water in Havells Water purifier?

Havells Water Purifier (FAB UTC ALKALINE) can purify upto 25 litre of water per hour. However, time taken for purification depends on the water quality, input pressure and life of the cartridges.

4. How will I get service or spare parts for my water purifier?

During the first year of usage, your product is fully covered under the warranty and service will be on demand. Please contact Havells Customer Care for service visit to your place.

Post warranty period, you can opt for either of the following two service contracts available:

1. ACMC (Annual Comprehensive maintenance contract):

Under this contract all electrical parts & service visit charges will be covered and all the filters will be covered with the below mentioned condition

Two times Preventive Maintenance Visit ,One time replacement of All the filters, Electrical parts like Internal pump, PCB, UV lamp, Wiring harness, & Solenoid Valve.

What not covered: Plastic parts

2. SCMC(Semi Comprehensive maintenance contract):

Two times Preventive Maintenance Visit ,One time replacement of All the filters Except RO Membrane, Electrical parts like Internal pump, PCB, UV lamp, Wiring harness, & Solenoid Valve.

What not covered: RO membrane & plastic parts.

5. Is the water from first purification cycle fit to drink?

No, it is not recommended to either store or drink the first fill water in the storage tank. Always discard the water from the first purification cycle that gets collected in the storage tank.

6. What should I do if there is no water in the storage tank?

In case there is no water in the storage tank, please check if inlet water supply is on and power is switched on. If none of this applicable, contact Havells Customer Care for further assistance.

7. Can I service the purifier on my own?

It is not recommended. Your water purifier should always be serviced by Havells Service Engineer. Always contact the customer care if you are facing any issue which requires service or opening of the device to check it.

8. What should I do if there is a leakage from the purifier?

First switch off the purifier from power switch and then turn off the diverter valve. Look for any visual improper fitment and contact Havells Customer Care for rectification.

9. How long the purified water stored in the storage tank can be used for drinking?

You can safely consume the purified water stored in the storage tank of your purifier for up to 2 days post purification. Just make sure that you store it away from direct sunlight. If the water is stored for more than 2 days due to any reason, then discard the complete water from the storage tank, refill the storage tank with purified water and consume it.

10. What should I do if any part of the purifier is broken?

In case any part is damaged on opening the packaging, please call the Havells Customer

Care immediately. Our trained service engineer will visit your home at the earliest and assist you.

11. Are Ultraviolet light harmful like radiations?

Radiation does not cross solid objects, like metal, plastic, hence UV radiation will never come out of UV disinfection column and harm anyone.

12. Is external pre-filter part of Purifier Unit, does it come with the product purchase as part of initial packaging? Is it free?

No, Havells Water Purifier does not come with external pre-filter. A pre-filter can be installed post water quality check of input water or on customer's demand. External pre-filter is available at an additional cost.

WARRANTY TERMS AND CONDITIONS

Havells India Ltd (HIL) offers limited warranty for this water purifier against defect arising from faulty design, workmanship and material subject to the following terms and conditions:

1. All electric and functional parts are covered under warranty for 1 year from the date of purchase.
2. Consumables including Membrane performance enhancer, sediment filter, activated carbon cartridge, RO membrane, Bacteriostatic alkaline & taste enhancer are not covered under warranty.
3. All consumables and pump carry Havells branded embedded foil (as per Recommendation & important instruction mentioned in content no.9).
4. Havells India Limited will offer two preventive maintenance checkups during this one year term of warranty. Only Havells India Limited authorized service personnel will carry out repairs under warranty.
5. Consumers shall promptly notify the company about any defect noticed and give the company or authorized personnel/representative adequate opportunity to inspect, test and rectify the defect.
6. The company or its representatives are entitled to retain the damaged or defective parts replaced under warranty on free charge basis.
7. The company's liability under warranty will be limited only to the concerned product and its defect, which occur under conditions of normal operations in home application, under proper usage and maintenance. It excludes any defect caused due to faulty care, maintenance, repair and alteration to the product or to its part by unauthorized personnel.
8. It is mandatory to provide original bill/invoice copy along with duly stamped warranty card at the time of any repair work being done by authorized representative.
9. This warranty is confined to the first purchase of the product only and is not transferable.
10. In the event of repair during the warranty period of the purifier, this warranty will thereafter continue and remain in force only for the unexpired period of the warranty. Replacement of part would be purely at the discretion of Havells India Limited, the same part will be replaced with the part model of price equivalent at the time of purchase.
11. The consumer will have no claim under this warranty in an event of any illness, sickness, death, personal injury, property or consequential damages arising either directly or indirectly due to utilization of product. Authorised Service Personnel will carry out repair under warranty)
12. Warranty is not applicable and will be void under the following heads/ circumstances:
 - a. If the warranty card presented to authorized service personnel at the time of service of the product is not duly filled and stamped by the dealer.
 - b. If the product is not operated or handled as per instruction given in the operating instruction booklet.
 - c. If the device is not installed in proper procedure specified.
 - d. If any defect caused due to improper electric circuit outside the device in the house or any defective electric supply.
 - e. If installation and any repair work is carried out by an unauthorized personnel and usage of consumables and parts by unauthorized personnel. (only Havells India Limited Authorised Service Personnel will carry out repair under warranty)

- f. If any damage caused due to transportation or shifting post installation from consumer's home.
 - g. If 12 months have expired from the date of purchase even though the device is not in use for anytime during warranty period for any reason.
 - h. If the damage is caused by pest infestation.
 - i. If product/item is not installed by company technician/ Authorised Personnel
 - j. If Havells water purifier is used for any purpose other than for home application purpose (not to be used for commercial purposes)
 - k. If damage to the product is caused by accidents, pests and vermin, lightning, wind, fire, floods, or acts of God
 - l. If any additional accessories were provided on the time of installation/service, the same will not be covered under standard product warranty.
 - m. If any external accessories supplied by the dealer.
13. Warranty does not cover visitation charges of service technician if this water purifier is installed beyond municipal limits of the city in which company's Authorized Service Center is situated/located. All expenses incurred in collecting the units or parts thereof from the company's authorized service center as well as expenses incurred from deputizing service personnel/technicians for conveyance and other incidentals, etc., shall be borne by the customer. Local charges for transportation and handling charges may vary by location. Customers are advised to verify in advance the aforementioned charges. If the customer wishes to bring the unit on his/her own to an authorized service center, such shall be at his/her own risks & consequences.
 14. Reinstallation or uninstallation of product based on customer demand and packing material, if used, will be chargeable.
 15. Warranty will not cover transportation cost in case customer is moving the product to another location.
 16. In case of any unpredicted situation and non -availability of spares, prevailing depreciation policy of Havells India Limited (subject to the sole discretion of Havells India Limited, may be changed without prior notice) will be applied to the product as a solution.
 17. Settlement of all claims and disputes arising out of and in relation to this water purifier shall be subject to Delhi jurisdiction only.
 18. Warranty does not cover defects arising due to causes beyond control like lightning, abnormal voltage, acts of god.
 19. The company or its Authorized Service Center reserves the right to retain any part or component replaced at its discretion in case of a defect discovered in the equipment during the warranty period.
 20. The warranty is valid within India only.



We are an environment conscious company and have started an initiative to dispose the product wastes like replaced parts and filters in an environment friendly manner. You are advised to handover the replaced parts and discarded filters to our service engineers and we will ensure that these parts are disposed of without causing any harm to the environment.

Diagrams or figures in this document are for illustration purposes only.

Copyright: Subsisits. Imitation of trade dress, graphics and color scheme of this document is a punishable offence.

Actual products may vary in colour, design, description and colour combination etc. Although every effort has been made to ensure accuracy in the compilation of the technical detail within this publication, Specifications & performance data are constantly changing.

061124/V1



Havells India Ltd.

QRG Tower, 2D, Sector-126, Expressway,
Noida - 201304. U.P. (INDIA)

E-mail: customercare@havells.com,
Website: www.havells.com

Customer Care No.: 08045 77 1313
WhatsApp No.: +91-9711773333

Join us on Facebook at www.facebook.com/havells & share your ways to save the planet!



WARRANTY CARD
HAVELLS WATER PURIFIER

Customer Name _____

Customer Address _____

Customer Phone Number _____

Pin Code _____

Date of Purchase _____

Dealer's Name & Address
Phone Number

Dealer's Stamp:

Product Model _____

Product Serial No. _____

* This warranty card is valid only for products sold by Havells India Limited in Indian market.
This warranty is not transferable and is applicable to the original purchaser only.



Fill out this record and keep it together with your purchase docket in a safe place. Should you require service under the terms of this warranty, please contact us.

Havells India Ltd.

QRG Tower, 2D, Sector-126, Expressway, Noida - 201304. U.P. (INDIA)

E-mail: customercare@havells.com, Website: www.havells.com

Customer Care No.: 08045 77 1313, WhatsApp No.: +91-9711773333

Join us on Facebook at www.facebook.com/havells & share your ways to save the planet!