

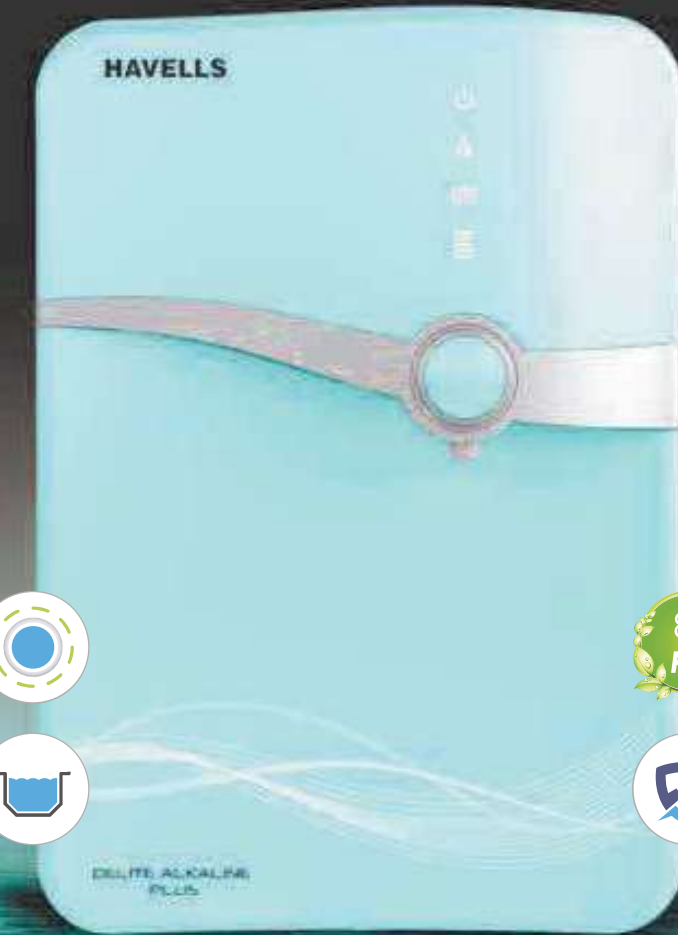

# Water Purifier

## User Manual

DELITE ALKALINE PLUS



HYGIENIC FLOW CONTROLLER



STAINLESS STEEL WATER TANK



ALKALINE WATER NATURE'S WAY



DOUBLE PROTECTION WITH 24\*7 TANK STERILIZATION

**DELITE ALKALINE PLUS**

100% RO & UV PURIFIED ALKALINE WATER  
SUITABLE FOR TDS UPTO 2000 mg/L (ppm)

\*pH may vary depending upon input water quality, life of alkaline cartridge & RO element

**Havells India Ltd.**

QRG Tower, 2D, Sector-126, Expressway, Noida - 201304. U.P. (INDIA)

E-mail: [customercare@havells.com](mailto:customercare@havells.com), Website: [www.havells.com](http://www.havells.com)

Customer Care No.: 08045 77 1313, WhatsApp No.: +91-9711773333

Join us on Facebook at [www.facebook.com/havells](http://www.facebook.com/havells) & share your ways to save the planet!

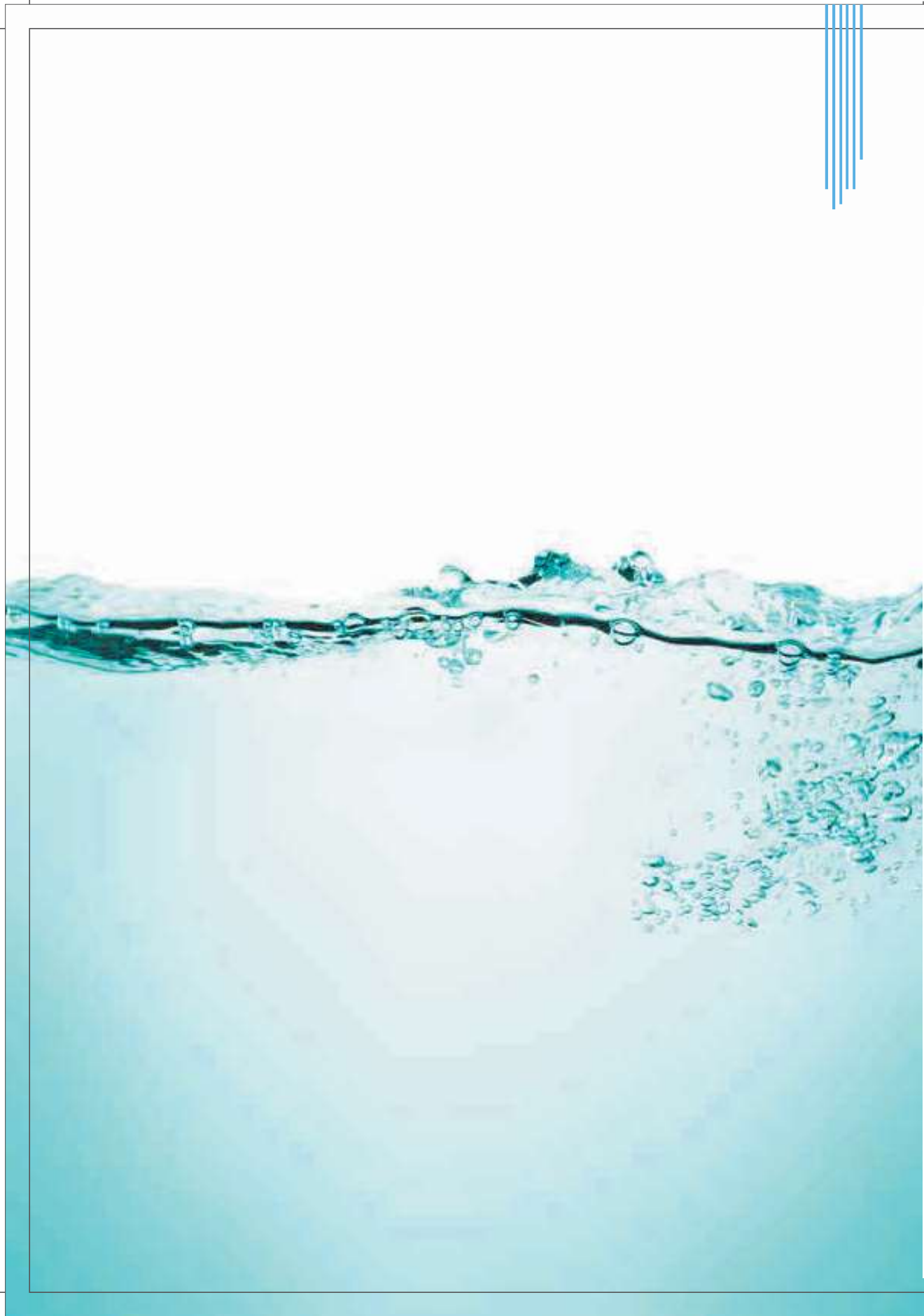

# CONTENTS

Welcome to Havells Water Purifiers.....	2
Product Overview.....	4
Technical Specifications .....	5
Stages of Purification .....	6
Water Flow Diagram .....	7
The Purification Process.....	8-9
Key Features of Havells Water Purifier.....	10-11
Functions of Smart Indicators .....	12
Installation Instructions .....	13
Do's, Don'ts & Safety Instructions.....	14-15
Cleaning and Maintenance .....	16
Recommendations and Important Instructions .....	17
Calibration & general maintenance instruction for hand held tds meter.....	18
How To Reuse The Flushed Water & Troubleshooting.....	19
FAQS.....	20-21
Warranty Terms and Conditions .....	22-23
Warranty Card & Havells Customer Care (We Care Service).....	24



## WELCOME TO HAVELLS WATER PURIFIERS

At Havells we believe in making a difference by touching every aspect of our consumers' lives through the products we make and bringing positive changes in it. Since the very beginning all our products have been manufactured keeping the highest standards of quality and innovation in mind and we make sure that they meet the world class standards that our consumers' demand. And this legacy continues unwaveringly when it comes to Havells Water Purifiers too.

Our experts with decades of experience in Water Purification Technology have been listening to the consumers and we understand that due to lack of adequate information, there are a lot of questions and confusion in the consumers' minds about the need of water purifiers today and how to choose a water purifier basis the water quality in their area. Water quality has changed drastically over the years and many water purifiers available in the market today are not effective to give protection from the new age pollutants and provide safe drinking water devoid of any impurity.

Keeping this in mind, we have designed and perfected a water purifier that recognizes the challenges of new age pollutants and removes them effectively. What makes Havells Water Purifier unique is the fact that it has a powerful purification process to remove all complex impurities, adds back wide spectrum of naturally occurring essential minerals and trace elements that were removed in the filtration process and makes it easier to absorb and hydrates your body.

It is our commitment that we continuously strive to make lives better for our consumers, so let's understand your water purifier better in the subsequent sections.

Dear Customer,

We welcome you to the ever growing family of happy Havells consumers. Havells is being trusted by millions of consumers all over the world for its quality products and efficient after sales service.

It's a matter of great pride for us that you've entrusted Havells Water Purifier for your family and home. Our experts with decades of experience in Water Purification Technology have been listening to the consumers like you and have developed this purifier keeping in mind your needs and demanding lifestyle.

We are confident that you will be satisfied with its performance and it will fulfill your need for providing clean and safe drinking water to your loved ones.

This manual is a simple and easy to understand step by step guide that explains everything you need to know about your water purifier and it will assist you to get the best performance out of it. Please go through this booklet to understand its operation and periodic maintenance.

However in case you have any query or you need further assistance, please feel free to contact us at Customer Care No.: 08045 77 1313 or e-mail us your concerns or suggestions at [customercare@havells.com](mailto:customercare@havells.com)

We thank you again for choosing Havells Water Purifier and assure you that your journey with us will be a delightful one.

Yours sincerely

Havells India Ltd.

# PRODUCT OVERVIEW - DELITE ALKALINE PLUS

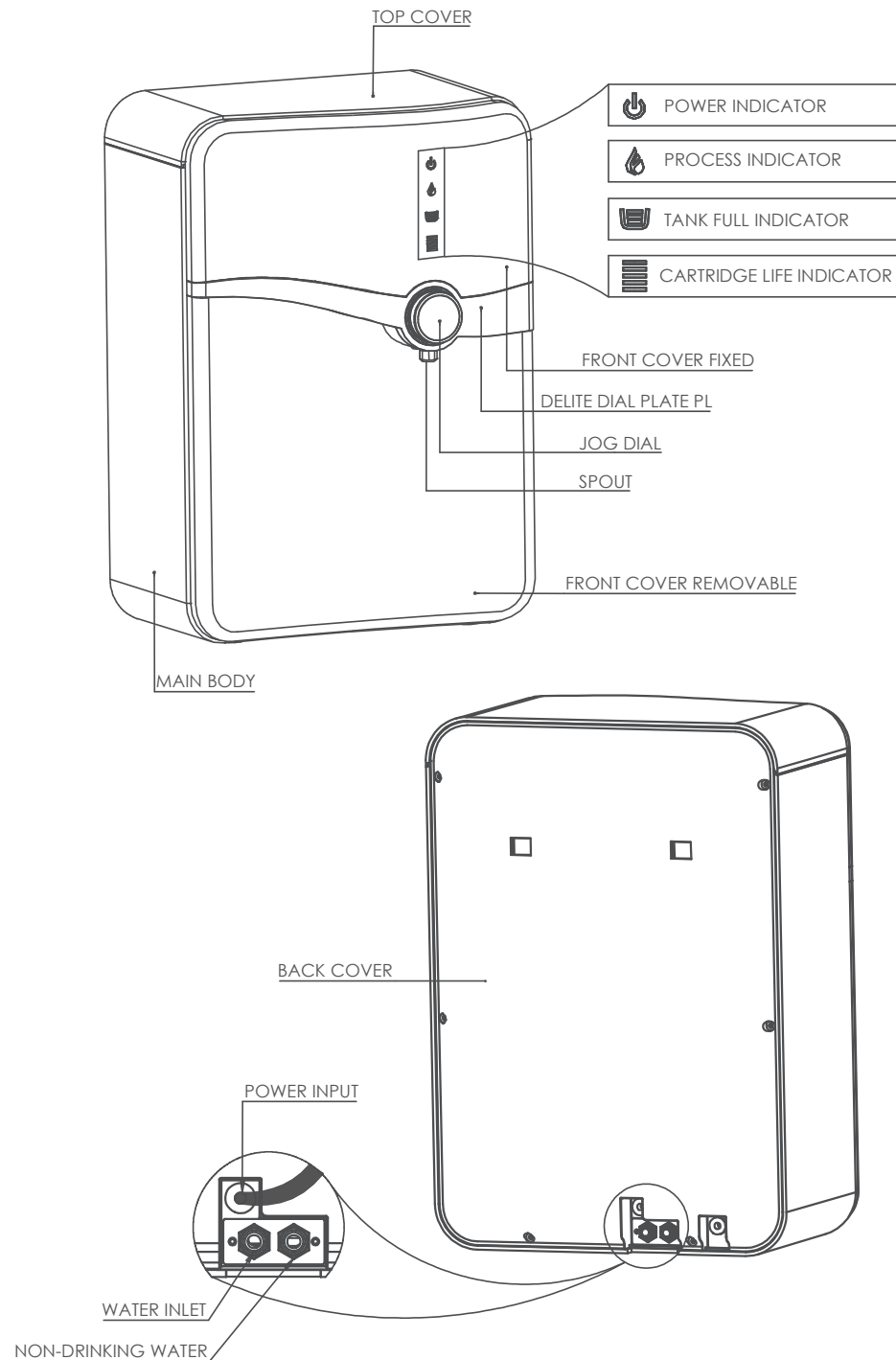

# TECHNICAL SPECIFICATIONS- DELITE ALKALINE PLUS

PARAMETERS	VALUES
Product dimensions (H x D x W) in cm	( 49.7 x 25.2 x 35.1 ) cm
Net weight	~ 9.5 kg
Flow rate*	Up to 25 L/h
Storage tank capacity	~ 6.5 L ± 300 ml
Purification technology	Absolute safety through 100% RO & UV LED technology
Purification stages	11 Stages
Membrane type#	Thin film composite RO membrane
Material of construction for plastic components	Food grade
Power rating (maximum)	60 W
Working voltage	1 Phase, 150 V- 250 V AC, 50 Hz
% Recovery**	≥ 40%
TDS reduction**	≥ 90%
System disinfection efficacy	6, 4, 3 Log reduction of bacteria, viruses & cysts
pH##	Purified Water pH in Alkaline range
Installation type	Wall mount & Counter top

## RECOMMENDED FEED WATER QUALITY

PARAMETERS	LIMITS
Total dissolved solids	Up to 2000 mg/L (ppm)
Total hardness	Up to 600 mg/L (ppm)
Turbidity***	Up to 5 NTU
Feed water pressure****	0.041 MPa (6 psi) - 0.21 MPa (30 psi)
Feed water temperature	5 °C - 45 °C
Iron*****	Less than 0.3 mg/L (ppm)
Free chlorine	Less than 0.2 mg/L (ppm)

### NOTE:

\*Flow Rate may vary depending upon feed water quality, input water pressure, condition of membrane & cartridges.  
\*\* Recovery / TDS percentage reduction may vary depending upon type of feed water, feed water pressure & cartridges life.

\*\*\*In case, input turbidity is more than 5 NTU, you need to install pre filter at an additional cost.

\*\*\*\*In case, input water pressure goes below 0.041 MPa (6 psi), you need to install external booster pump and if pressure is above 0.21 MPa (30 psi), you need to install pressure reducing valve at an additional cost.

\*\*\*\*\*In case, the Iron content in input water is more than 0.3 mg/L (ppm), you need to install IRON REMOVER PLUS at an additional cost.

#The chemical preservative used in the RO membrane is of food grade quality.

##Under Standard test conditions of Alkaline Cartridge ( as per BIS standard IS 10500:2012)

# STAGES OF PURIFICATION - Delite Alkaline Plus

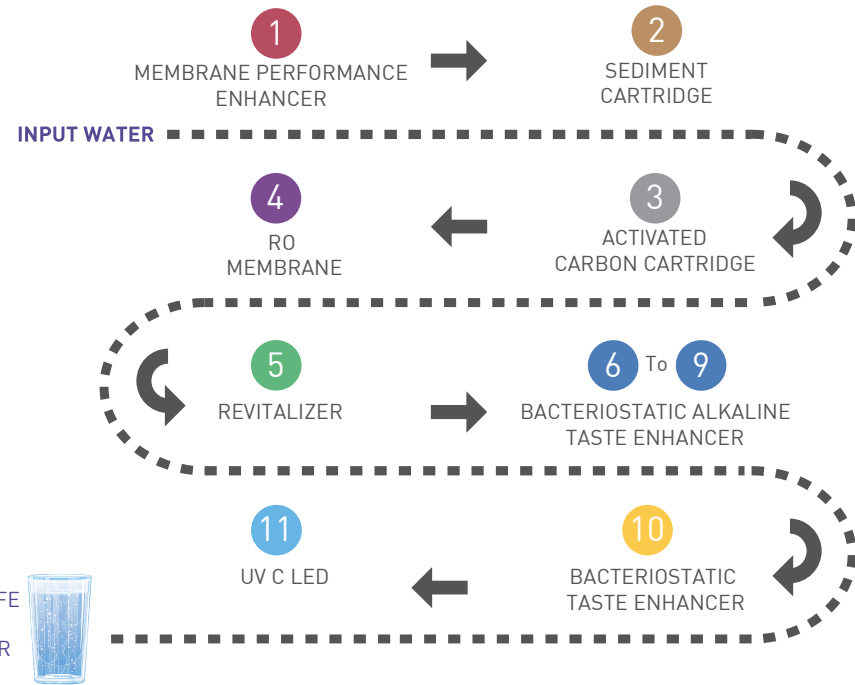

# WATER FLOW DIAGRAM - Delite Alkaline Plus

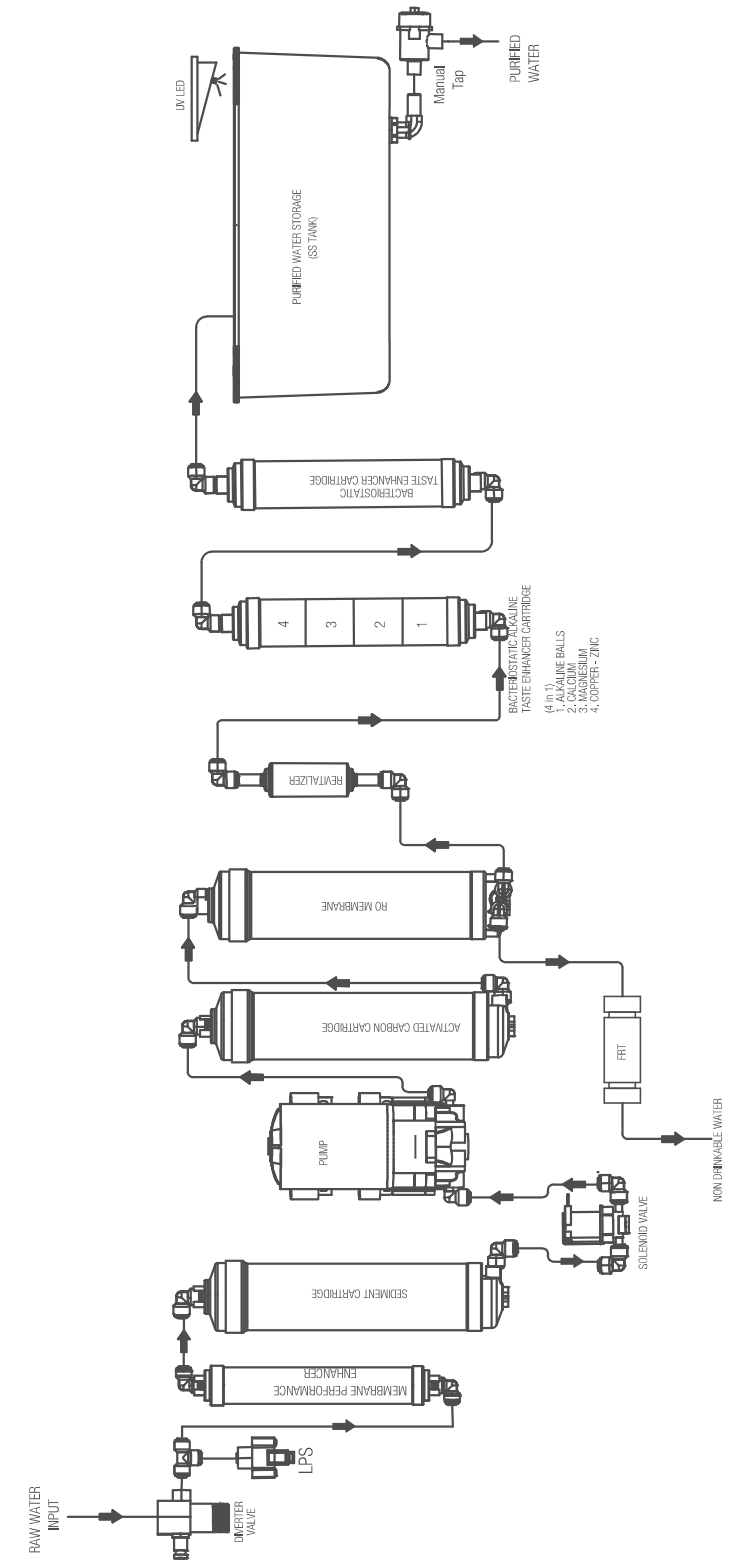

# THE PURIFICATION PROCESS

Havells Water Purifiers have a powerful purification process which is divided in to 3 Phases viz. Pre-Treatment, Purification & Value Additions. In pretreatment process water will pass through Membrane Performance Enhancer, Sediment Filter and Activated Carbon Filter. During the purification process 100% water passes through RO Membrane followed by Germicidal UV C LED disinfection in storage tank.

Water will pass through a controlled bipolar magnetic field which realigns the water molecules and make it better or more bioavailable and pH of water will be enhanced, minerals will be added to purified water and in the final stage of purification Bacteriostatic Taste Enhancer will improve the taste of purified water. The names of all the cartridges along with their functions and benefits are explained in the table below for better understanding

## 1 MEMBRANE PERFORMANCE ENHANCER

It prevents scaling formation on RO Membrane due to hardness in feed water, which results in improved performance and enhances the life of RO membrane.



## 2 SEDIMENT CARTRIDGE

Sediment Cartridge removes coarse and fine suspended impurities such as sand, silt, dust, clay, rust particles etc. from the feed water and makes it clear. This improves the performance and the life of activated carbon cartridge and the RO membrane.

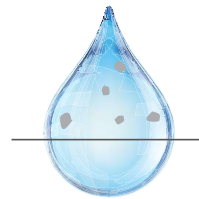

## 3 ACTIVATED CARBON CARTRIDGE

Activated Carbon, filter-cum-adsorber Cartridge removes a wide range of dissolved organic impurities like pesticides and herbicides along with residual chlorine and its by-products (THMs) present in the water. It also removes colour & objectionable odour from water. This in turn improves the taste of the water.

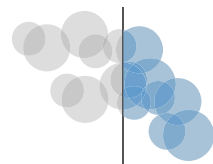

## 4 REVERSE OSMOSIS MEMBRANE

Reverse Osmosis Membrane removes dissolved contaminants such as dissolved solids, salinity, pesticides, herbicides as well as hazardous heavy metals like Arsenic, Chromium, Lead and Fluorides etc. It also removes harmful microbiological impurities such as bacteria, viruses and cysts from the feed water. It ensures absolutely safe and pure drinking water.



## 5 REVITALIZER CARTRIDGE

Revitalizer Cartridge realigns the water molecules and makes it biologically active. It improves the hydration and mineral absorption in body.



## 6 BACTERIOSTATIC ALKALINE TASTE ENHANCER

To It enhance the pH of purified water by adding back wide spectrum of natural minerals & trace elements such as Calcium, Magnesium, Potassium, Sodium, Copper, Zinc, etc. It lowers the Oxidation Reduction Potential (ORP) resulting into anti-oxidant nature of water, transforms regular water into Alkaline Water, which is healthier & tastier.



## 10 BACTERIOSTATIC TASTE ENHANCER

Bacteriostatic Taste Enhancer removes organic residues and VOC. It enhances the taste of purified water and gives it a sparkling texture.



## 11 GERMICIDAL UV C LED

An optimum exposure of water to Germicidal UV C LED in storage tank makes water free from microbiological threats like pathogenic bacteria and viruses. UV LED prevents the Bio Film formation. Maintains hygiene of water and stainless steel tank.



# KEY FEATURES OF HAVELLS WATER PURIFIER

## A. DOUBLE PROTECTION: 100 % RO + GERMICIDAL UV LED PURIFICATION WITH 24\*7 TANK STERILIZATION

**Absolute Safety through 100% RO Purified Water:**  
100% Water passes through the RO Membrane to ensure absolutely safe and pure drinking water.

**Purification through Germicidal UV C LED:**  
An optimum exposure of water to germicidal UV-C radiation in storage tank makes water free from microbiological threats like pathogenic bacteria and viruses.

**24\*7 Tank Sterilization:**  
UV LED prevents the Bio-film formation.  
Maintains hygiene of water and stainless steel tank.

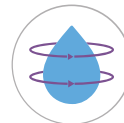

## B. BACTERIOSTATIC ALKALINE TASTE ENHANCER

It enhance the pH of purified water by adding back wide spectrum of natural minerals & trace elements such as Calcium, Magnesium, Potassium, Sodium, Copper, Zinc, etc. It lowers the Oxidation Reduction Potential (ORP) resulting into anti-oxidant nature of water, transforms regular water into Alkaline Water, which is healthier & tastier.

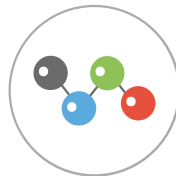

## C. BACTERIOSTATIC TASTE ENHANCER

Bacteriostatic Taste Enhancer removes organic residues and VOC. It enhances the taste of purified water and gives it a sparkling texture.



## D. MEMBRANE PERFORMANCE ENHANCER

It prevents scaling formation on RO Membrane due to hardness in feed water, which results in improved performance and enhances the life of RO membrane.



## E. REVITALIZER CARTRIDGE:

It realigns the water molecules and makes it biologically active. It improves the hydration and mineral absorption in body

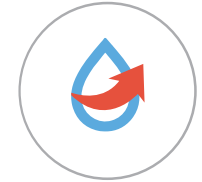

## F. CARTRIDGE LIFE INDICATOR:

Monitors and displays the filter life expectancy to help you plan comprehensive maintenance in advance.



## G. INGRESS PROTECTION TANK COVER:

Stops external invasion of insects and dust particles.

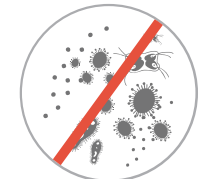

## H. i PROTECT PURIFICATION MONITORING:

Constantly monitors the purification process, and ensures safe water.



## I. HYGIENE FLOW CONTROLLER:

Hygienic flow control faucet with easy to dispense & zero splash of water.



## J. CONTEMPORARY DESIGN & AESTHETICS:

Futuristic design, superior dual tone colour finish, compact design and functional display panel, compliment your kitchen décor.





## FUNCTIONS OF SMART INDICATORS



POWER INDICATOR



PROCESS



TANK FULL



FILTER LIFE

### SELF-DIAGNOSTIC MODE

When machine is switched – ON, all the indicators will glow for a fraction of second, Where system warms up and check components is working fine. After that, the power indicator will glow solid.

### PURIFICATION PROCESS INDICATOR

After 5 seconds, process indicator will glow solid for 30 seconds to indicate tank sterilization process is ON. Later the purification process will start and purification process indicator will blink till the tank is full.

### TANK FULL INDICATOR

Tank Full Indicator glows solid when the tank is full.

### HYGIENE FLOW CONTROLLER FOR WATER DISPENSING

Hygienic flow control faucet with easy to dispense & zero splash of filtered water stored in SS tank.

### PERIODIC DISINFECTION

If water is not dispensed from the system for 4 hours, periodic UV sterilisation cycle will start and the water stored in tank will be disinfected by exposing UV light for 20 minutes. During the process, water tank storage will also irradiate with UV radiation.

The periodic treatment process ensures safe drinking water and sterilised water storage tank at all times. During this cycle, all indication will glow solid.

### FILTER LIFE

Your Filters life is counted, on the basis of the usage. One by one the bars of filter life indication will turn off with reducing life. On completion of 90% life of filters, last bar of filter life indication will start blinking. This is the time to call Havells service for change of filter.

On completion of 100% life 'Filter life indication' (all 5 bars) will start blinking with buzzer. This is the time to replace your filters.

### ERROR INDICATION

In the event of failure of Pump and main SV, power indicator will start blinking with 1 beep buzzer sound. In case of UV LED fails, power indicator will start blinking with 2 beep buzzer sound. System will shut off in the cases to deliver you the promise of safe water or no water.

In case of low pressure condition (Input water pressure is not adequate) then tank indication will blink.

## INSTALLATION INSTRUCTIONS

1. Open the carton and take out the following items from accessory box for installation:
  - a. Diverter valve
  - b. Mounting plate with plastic inserts and mounting screws
  - c. PL 4 pipe-White and Blue
2. Select an appropriate water connection point.
3. Please note water purifier is connected to ambient temperature water supply only.
4. Fix diverter valve with the help of pipe wrench/plumbing equipment's at selected water point.
5. For wall mounting: Align the mounting plate at appropriate height and fix it with the help of mounting screws. Hang the water purifier on mounting plate.

OR

Place the water purifier on counter top.

6. Fix the water inlet pipe (white pipe) from diverter valve to the feed water inlet port of water purifier and open the diverter valve. Ensure there is no leakage of water and bending of pipe at any point.
7. Outlet pipe (blue pipe) is connected to non drinking water outlet port of purifier.
8. Fix the power plug into a 3 pin socket.
9. Switch ON the mains, unit will start working.
10. It is advised to drain the first fill of water tank after installation of the water purifier or after changing the filters. This water can be used for washing, cleaning and other household purpose.

**Caution:** Before installation/mounting:-Flush all filters thoroughly and independently for 3 minutes - 5 minutes to remove fine particles & preservatives present in filters.

Check input water pressure. Use booster pump if feed water pressure is less than 0.041 MPa (6 psi) if it is more than 0.21 MPa (30 psi) use the PRV (Pressure reducing valve). If the input water iron content is more than 0.3 mg/L (ppm), use of iron remover is recommended as a pre-treatment. If input water turbidity is more than 5 NTU, use of Pre filter is suggested.

The appliance is intended to be permanently connected to the water mains and not connected by a hose-set

# DO'S, DON'TS & SAFETY INSTRUCTIONS

## DO'S ✓

Always install the water purifier in a cool, dry and well ventilated place in upright position.

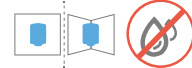

Keep the tank lid closed properly to avoid contamination of water due to exposure to dust, dirt or insects.



To keep your purifier functioning properly at all times, always use Havells genuine spare parts.



Call only Havells customer care for any assistance and service requirement.



Keep the purifier in power on mode to ensure 24 x 7 tank sterilization and also water availability at all times, it is safe & consumes less power in a day.



If for any reason you are not going to use the water purifier for a long time, for e.g. during a holiday, then make sure that you disconnect the power supply, turn off the input water supply and drain the storage tank.



## DON'TS ✗

Never allow hot water to pass in your water purifier as it is designed to work effectively between input water supply of temperature range between 5 °C to 45 °C



Never place any heavy, sharp or wet objects on the purifier.



Do not buy local spare parts and components during service or replacement in case of a breakdown.



Do not install product in direct sunlight.



Do not use chemicals or detergents to clean the storage tank . It can be harmful to human body

## SAFETY INSTRUCTIONS

Havells Water Purifier is designed keeping in mind the highest safety standards, but there are certain safety precautions that need to be followed while using the product for its proper functioning.

Do not move or relocate the purifier when it's running.



To avoid electric shock, do not pull out or touch the power plug with wet hands.



Do not use the water purifier if the power cord is damaged or if there's a strange noise, burning smell or smoke. Quickly switch off the power, unplug the cord and call Havells Customer Care.



Don't open the purifier yourself to clean the cartridges or to replace any parts.



Never use the discarded water from the purifier tube for drinking. However it can be used for cleaning, washing, mopping, gardening etc.



This appliance is not intended for use by persons (including children) with reduced physical, sensory or mental capabilities, or lack of experience and knowledge, unless they have been given supervision or instruction concerning use of the appliance by a person responsible for their safety. Children should be supervised to ensure that they do not play with the appliance. If the supply cord is damaged, it must be replaced by the manufacturer, its service agent or similarly qualified persons in order to avoid a hazard.

## CLEANING AND MAINTENANCE

Storage Tank of this product must be \* periodically cleaned (at least once in 6 months, during Preventive service ) by use of 4-5 drops of disinfectant like hypochlorite solution to water purifier tank (tank full), keep it for 15 minutes. Discard the disinfectant water and the first fill of water tank completely through water dispensing tap.  
\* As per customer need.



Use a wet cloth to clean the external body of the purifier. Do not use detergent or soap.



Avoid excessive rubbing of the decorative part of the purifier while cleaning as it may lead to scratches or loss of shine of the purifier.



Make sure you switch off the power supply and diverter valve whenever you're out of home for a long time.



Do not try to open or tamper the purifier yourself if you observe any problem. Kindly contact Havells Customer Care to resolve the issue. Water purifier should be examined by Havells trained service engineer only at all times.



Do not clean the water purifier or spillage of water on it, while the purification process is on.



## RECOMMENDATIONS AND IMPORTANT INSTRUCTIONS

### RECOMMENDED CARTRIDGE CHANGE

#### Recommended Cartridge Replacement:

Membrane Performance Enhancer Cartridge, Sediment Cartridge, Activated Carbon Cartridge and Bacteriostatic Taste Enhancer Cartridge need to be replaced after 1 year of installation or after dispensing 6000 litres\* of purified water, whichever is earlier.



#### RO (Reverse Osmosis) Membrane Replacement:

As per the warranty, RO Membrane needs to be replaced after 1 year of installation or after dispensing 6000 litres\* of purified water, whichever is earlier.



#### Bacteriostatic Alkaline Taste Enhancer:

Bacteriostatic Alkaline taste enhancer Cartridge needs to be replaced after 6 months of installation or after dispensing of 3000 L\* of purified water, which is earlier.



#### Tank UV LED:

UV LED needs to be replaced after burning of 5000 hours or based on service requirement.

Note: Please read the warranty details and their terms and conditions for replacement requirement of individual cartridges.

\* May vary depending on the feed water quality.

# CALIBRATION & GENERAL MAINTENANCE INSTRUCTION FOR HAND HELD TDS METER

The functioning of the TDS Meter will be ascertained by our authorized service representative periodically (at least once in 6 months, during Preventive service) or as per the customer request.

## For Calibration

1. Take the 100 ml water of standard solution in a beaker.
2. Carefully immerse the probes of the TDS Meter in the standard calibration solution and turn ON the TDS meter.
3. The TDS of water will display, wait for 10 seconds - 20 seconds to stable the reading.
  - i. If value matches with the standard calibration solution ( $\pm 10\%$ ) then calibration is considered as completed.
  - ii. If the value does not match with the standard calibration solution then follow below instructions
    - a. To adjust the readings, long press the HOLD icon for 3 seconds. Hold will starts blinking on display.
    - b. Then press the Temp. icon. TDS of the standard calibration solution will display and blinks on the display to indicate that calibration is completed.
4. Remove the TDS meter from the solution. Clean the probe by purified water and dry it with the help of cloth/cotton.
5. Turn the meter off, wait for a moment & turn ON the meter again to start using.

## For General Usage & Maintenance

1. Immerse the meter in the water/solution such that the probes are completely dipped in it.
2. Shake & clean with purified water after each use.
3. The meter is not water proof. DO NOT drop or submerge the meter in water.
4. Do not store the meter in high temperature or direct sunlight.
5. Replace the battery if the display is dim or readings are consistently not accurate.

## Important Notes.

1. TDS Meter Range: From 0 mg/L to 2000 mg/L.
2. Tolerance:  $\pm 10\%$  of water TDS.
3. Depending on the make of the meters, the calibration buttons may be "on/off" or "hold" or a combination of both. Contact authorized Havells service technician for support.

# HOW TO REUSE THE FLUSHED WATER

Although the flushed water from the purifier has high concentration of TDS and hardness, it can still be used for following activities:

- Can be used for watering the plants



- Can be used for mopping and cleaning the floor



- Can be used to clean bathroom



# TROUBLESHOOTING

	PROBLEMS	CHECKS	SOLUTIONS
Before calling customer care or service engineer, check the following points:  1. Power supply should be ON 2. Inlet water supply should have sufficient pressure/ Waterflow	Purified Water taste is bad or unusual	1. Is the tank clean? 2. Is purified water being stored in the tank for a long time? 3. Is the Cartridge replacement due as per the service requirement?	1. Clean the storage tank. 2. Discard the water stored in tank and clean the tank before starting the purification process again. 3. Contact Havells Customer Care to request for the cartridge replacement.
	Filtration time is very long/short or filtration has stopped/too much water is being purified.	1. Is the tap valve open properly? 2. Is water pressure below recommended value? 3. One or more Cartridges may have been clogged or damaged.	1. Open the water inlet valve completely. 2. Contact Havells Customer Care to get the pressure checked and get it resolved. 3. Contact Havells Customer Care to get the cartridges replaced.
	Very less or no water is being flushed out.	1. Check if the flushed water tube (Blue colour pipe) is bent anywhere. 2. Check if the flushed water tube is blocked in any place.	1. Remove the bend in the flush water tube if found. 2. Switch off the purifier and contact Havells Customer Care for proper checking the product.
	Water leakage in any part.	Check if water is coming out from storage tank of the purifier or some other pipe.	Close the water inlet valve, unplug the power cord and then contact Havells Customer Care for a check-up of the product and get it rectified.

# FAQs

1. What is TDS?

TDS stands for Total Dissolved Solids in water. This affects taste of water and beverages prepared with such water.

2. Is the purification process completely automated or a manual intervention is required?

The purification process is completely automatic. Purification starts when water level goes down and stops once water tank is full.

3. How much time does it take to purify water in Havells Water purifier?

Havells water purifier (Delite Alkaline plus) can purify up to 25 litres of water per hour. However, time taken for purification depends on the water quality, input pressure and Life of the cartridges.

4. How will I get service or spare parts for my water purifier?

During the first year of usage, your product is fully covered under the warranty period and service will be on demand. You only need to contact the Havells Customer Care by either calling or and request a visit to your place to replace the cartridges or spare parts. Post the 1 year warranty period is over, you can opt for either of the following two service contracts available:

**1. APMC (Annual Comprehensive maintenance contract):**

Under this contract electrical parts & service visit charges will be covered and the filters will be covered as mentioned below.

**What covered:** Two times Preventive Maintenance Visit ,One time replacement of All the filters, Electrical parts like Internal pump, PCB, UV LED, Wiring harness, & Solenoid Valve

**What not covered:** Plastic parts

**2. SCMC (Semi Comprehensive maintenance contract):**

Under this contract the consumables like filters will be covered except RO membrane as mentioned below.

What Covered: Two times Preventive Maintenance Visit ,One time replacement of All the filters Except RO Membrane, Electrical parts like Internal pump, PCB, UV LED, Wiring harness, & Solenoid Valve.

**What not covered:** RO membrane & plastic parts.

5. Is the water from first purification cycle fit to drink?

No, it is not recommended to either store or drink the first fill water in the storage tank. Always discard the water from the first purification cycle that gets collected in the storage tank.

6. What should I do if there is no water in the storage tank?

In case there is no water in the storage tank, then check if there is proper water supply in the inlet pipe and power is switched on. If none of this applicable, contact Havells Customer Care for further assistance.

7. Can I service the purifier on my own?

It is not recommended. Your water purifier should always be serviced by a trained Havells Service Engineer. Always contact the customer care if you are facing any issue which requires service or opening of the device to check it.

8. What should I do if there is a leakage from the purifier?

First switch off the purifier from power switch and then turn off the diverter valve. Look for any visual improper fitment and contact Havells Customer Care for rectification.

9. How long the purified water stored in the storage tank can be used for drinking?

You can safely consume the purified water stored in the storage tank of your purifier for up to 2 days post purification. Just make sure that you store it away from direct sunlight. If the water is stored for more than 2 days due to any reason, then kindly discard the complete water from the storage tank, refill the storage tank with purified water and then only consume it.

10. What should I do if any part of the purifier is broken?

In case any part is damaged on opening the packaging, pls call the Havells Customer Care immediately. Our trained service engineer will visit your home at the earliest and assist you with the required repair.

11. Are Ultraviolet light harmful like radiations?

Radiation does not permeate solid objects, like metal sheet, plastic jacket, hence UV radiation will never come out of storage tank and harm anyone. Direct eye or skin contact with a freely emitting UV source is hazardous.

12. Is extra pre-sediment filter part of Purifier Unit, does it come with the product purchase as part of initial packaging? Is it free?

No, Havells Water Purifier does not come with additional pre-filter during the time of purchase in the original package. A pre-filter can be installed post doing a water quality check of input water or on customer's demand. Pre-sediment filter is available at an additional cost.

**Revision History**

Sl. No.	Revision No.	Revision date	Revision details
1	01	13.11.2024	User Manual amended as per IS 16240:2023 guidelines

# WARRANTY TERMS AND CONDITIONS

Havells India Ltd (HIL) offers limited warranty for this water purifier against defect arising from faulty design, workmanship and material subject to the following terms and conditions:

1. All electric and functional parts are covered under warranty for 1 year from the date of purchase.
2. Consumables including membrane performance enhancer, sediment cartridge, activated carbon cartridge, RO membrane, bacteriostatic Alkaline taste enhancer cartridge & Bacteriostatic taste enhancer cartridge are not covered under warranty.
3. All consumables and pump carry Havells branded embedded foil (as per Recommendation & important instruction mentioned in content no.9)
4. Havells India Limited will offer two preventive maintenance checkups during this one year term of warranty. Only Havells India Limited authorized service personnel will carry out repairs under warranty.
5. Consumers shall promptly notify the company about any defect noticed and give the company or authorized personnel/representative adequate opportunity to inspect, test and rectify the defect.
6. The company or its representatives are entitled to retain the damaged or defective parts replaced under warranty on free charge basis.
7. The company's liability under warranty will be limited only to the concerned product and its defect, which occur under conditions of normal operations in home application, under proper usage and maintenance. It excludes any defect caused due to faulty care, maintenance, repair and alteration to the product or to its part by unauthorized personnel.
8. It is mandatory to provide original bill/invoice copy along with duly stamped warranty card at the time of any repair work being done by authorized representative.
9. This warranty is confined to the first purchase of the product only and is not transferable.
10. In the event of repair during the warranty period of the purifier, this warranty will thereafter continue and remain in force only for the unexpired period of the warranty. Replacement of part would be purely at the discretion of Havells India Limited, the same part will be replaced with the part model of price equivalent at the time of purchase.
11. The consumer will have no claim under this warranty in an event of any illness, sickness, death, personal injury, property or consequential damages arising either directly or indirectly due to utilization of product. Authorized Service Personnel will carry out repair under warranty)
12. Warranty is not applicable and will be void under the following heads/ circumstances:
  - a. If the warranty card presented to authorized service personnel at the time of service of the product is not duly filled and stamped by the dealer.
  - b. If the product is not operated or handled as per instruction given in the operating instruction booklet.
  - c. If the device is not installed in proper procedure specified.
  - d. If any defect caused due to improper electric circuit outside the device in the house or any defective electric supply.
  - e. If installation and any repair work is carried out by an unauthorized personnel and usage of consumables and parts by unauthorized personnel. (only Havells India Limited Authorized Service Personnel will carry out repair under warranty)
  - f. If any damage caused due to transportation or shifting post installation from consumer's home.
  - g. If 12 months have expired from the date of purchase even though the device is not in use for anytime during warranty period for any reason.
  - h. If the damage is caused by pest infestation.
  - i. If product/item is not installed by company technician/ Authorized Personnel
  - j. If Havells water purifier is used for any purpose other than for home application purpose ( not to be used for commercial purposes)

- k. If damage to the product is caused by accidents, pests and vermin, lightning, wind, fire, floods, or acts of God
  - l. If any additional accessories were provided on the time of installation/ service, the same will not be covered under standard product warranty.
  - m. If any external accessories supplied by the dealer.
13. Warranty does not cover visitation charges of service technician if this water purifier is installed beyond municipal limits of the city in which company's Authorized Service Center is situated/located. All expenses incurred in collecting the units or parts thereof from the company's authorized service center as well as expenses incurred from deputizing service personnel/technicians for conveyance and other incidentals, etc., shall be borne by the customer. Local charges for transportation and handling charges may vary by location. Customers are advised to verify in advance the aforementioned charges. If the customer wishes to bring the unit on his/her own to an authorized service center, such shall be at his/her own risks & consequences.
  14. Reinstallation or uninstallation of product based on customer demand and packing material, if used, will be chargeable.
  15. Warranty will not cover transportation cost in case customer is moving the product to another location.
  16. In case of any unpredicted situation and non -availability of spares, prevailing depreciation policy of Havells India Limited (subject to the sole discretion of Havells India Limited, may be changed without prior notice) will be applied to the product as a solution.
  17. Settlement of all claims and disputes arising out of and in relation to this water purifier shall be subject to Delhi jurisdiction only.
  18. Warranty does not cover defects arising due to causes beyond control like lightening, abnormal voltage, acts of god.
  19. The company or its Authorized Service Center reserves the right to retain any part or component replaced at its discretion in case of a defect discovered in the equipment during the warranty period.
  20. The warranty is valid within India only.

## **10 YEAR Stainless Steel Tank WARRANTY\***

### **\*(1-year Standard Warranty + Additional 9 years Stainless Steel Tank Warranty)**

\*Warranty on Rusting of Stainless-Steel Tank

\* Additional 9-year Warranty on Stainless – Steel Tank after completion of 1 year Standard Warranty

\* No accidental damages will be covered

\* No other parts will be covered other than the Stainless-Steel Tank

\* Service charges to be payable by customer after 1 year Standard Warranty

**We are an environment conscious company and have started an initiative to dispose the product wastes like replaced parts and filters in an environment friendly manner. You are advised to handover the replaced parts and discarded filters to our service engineers and we will ensure that these parts are disposed of without causing any harm to the environment.**

Diagrams or figures in this document are for illustration purposes only.

Copyright Subsists. Imitation of trade dress, graphics and color scheme of this document is a punishable offence.

Actual products may vary in colour, design, description and colour combination etc. Although every effort has been made to ensure accuracy in the compilation of the technical detail within this publication, Specifications & performance data are constantly changing.

**WARRANTY CARD  
HAVELLS WATER PURIFIER**

Customer Name \_\_\_\_\_

Customer Address \_\_\_\_\_

Customer Phone Number \_\_\_\_\_

Pin Code \_\_\_\_\_

Date of Purchase \_\_\_\_\_

Dealer's Name & Address  
Phone Number

Dealer's Stamp:

Product Model \_\_\_\_\_

Product Serial No. \_\_\_\_\_

\* This warranty card is valid only for products sold by Havells India Limited in Indian market.  
This warranty is not transferable and is applicable to the original purchaser only.



Fill out this record and keep it together with your purchaser docket in a safe place. Should you require service under the terms of this warranty, please contact us.

**Havells India Ltd.**

QRG Tower, 2D, Sector-126, Expressway, Noida - 201304. U.P. (INDIA)

E-mail: [customercare@havells.com](mailto:customercare@havells.com), Website: [www.havells.com](http://www.havells.com)

Customer Care No.: 08045 77 1313, WhatsApp No.: +91-9711773333

Join us on Facebook at [www.facebook.com/havells](http://www.facebook.com/havells) & share your ways to save the planet!

