



HAVELLS

Water Purifier

User Manual

25 LPH

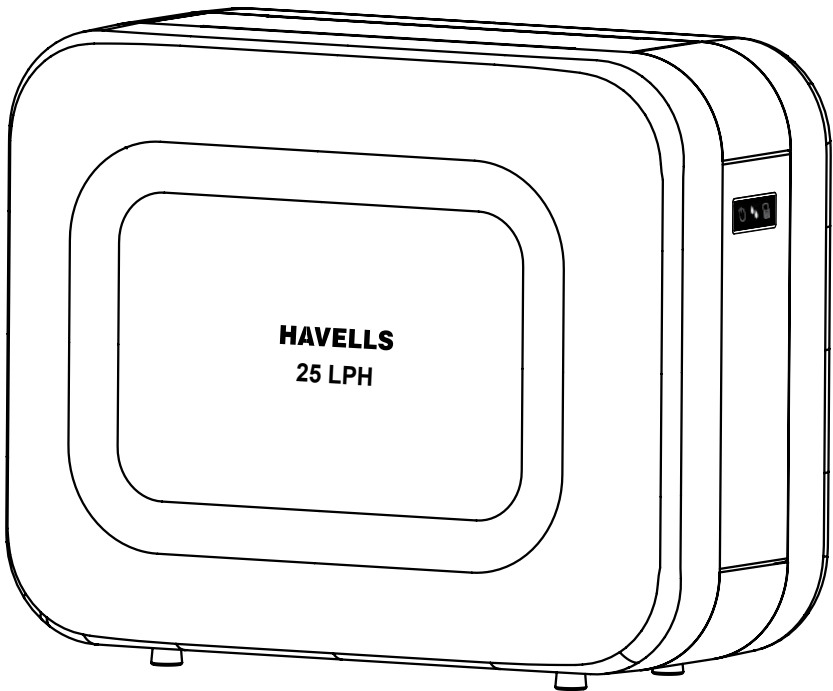

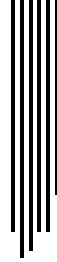

CONTENTS

Welcome to Havells water purifiers	3
Product overview	5
Technical specifications	6
Stages of purification	7
Water flow diagram.....	8
The purification process	9-10
Key features of Havells water purifier.....	11
Functions of smart indicators	12
Installation instructions	13
Do's, Don'ts & safety instructions	14-15
Cleaning and maintenance	16
Important instructions.....	17
How to reuse the flushed water	18
Troubleshooting	19
FAQs	20
Warranty terms and conditions	21-22
Havells Customer Care, Warranty Card	23



HAVELLS

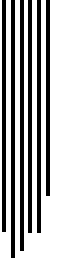

WELCOME TO HAVELLS WATER PURIFIERS

At Havells we believe in making a difference by touching every aspect of our consumers' lives through the products we make and bringing positive changes in it. Since the very beginning all our products have been manufactured keeping the highest standards of quality and innovation in mind and we make sure that they meet the world class standards that our consumers demand. And this legacy continues unwaveringly when it comes to Havells Water Purifiers too.

Our experts with decades of experience in Water Purification Technology have been listening to the consumers and we understand that due to lack of adequate information, there are a lot of questions and confusion in the consumers' minds about the need of water purifiers today and how to choose a water purifier basis the water quality in their area. Water quality has changed drastically over the years and many water purifiers available in the market today are not effective to give protection from the new age pollutants and provide safe drinking water devoid of any impurity.

Keeping this in mind, we have designed and perfected a water purifier that recognizes the challenges of new age pollutants and removes them effectively. What makes Havells Water Purifier unique is the fact that it has a powerful purification process to remove all complex impurities, adds back wide spectrum of naturally occurring essential minerals and trace elements that were removed in the filtration process and makes it easier to absorb and hydrates your body.

It is our commitment that we continuously strive to make lives better for our consumers, so let's understand your water purifier better in the subsequent sections.



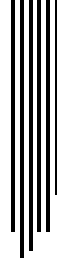

Dear Customer,

We welcome you to the ever growing family of happy Havells consumers. Havells is being trusted by millions of consumers all over the world for its quality products and efficient after sales service.

It's a matter of great pride for us that you've entrusted Havells Water Purifier for your family and home. Our experts with decades of experience in Water Purification Technology have been listening to the consumers like you and have developed this purifier keeping in mind your needs and demanding lifestyle.

We are confident that you will be satisfied with its performance and it will fulfill your need for providing clean and safe drinking water to your loved ones.

This manual is a simple and easy to understand step by step guide that explains everything you need to know about your water purifier and it will assist you to get the best performance out of it. Please go through this booklet to understand its operation and periodic maintenance.

However in case you have any query or you need further assistance, please feel free to contact us at 08045 77 1313 or e-mail us your concerns or suggestions at customercare@havells.com

We thank you again for choosing Havells Water Purifier and assure you that your journey with us will be a delightful one.

Yours sincerely

Havells India Ltd.

PRODUCT OVERVIEW MODEL - 25 LPH

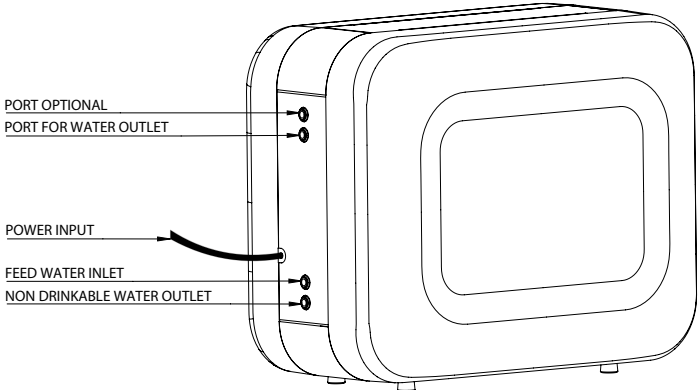
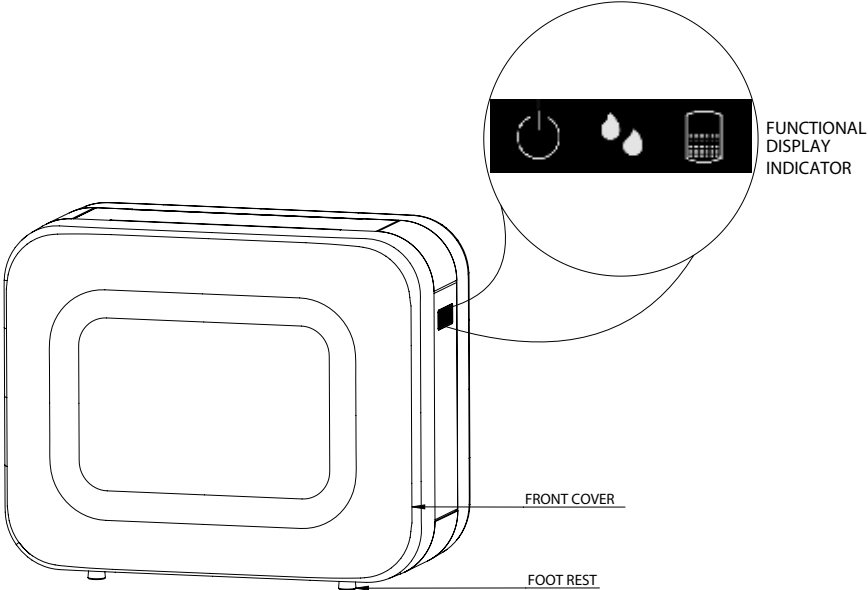

TECHNICAL SPECIFICATIONS

PARAMETERS	VALUES
Product dimensions (H x D x W) in cm	(38 x 45 x 24) cm
Net weight	~ 14.0 kg
Flow rate*	Up to 25 L/h
Purification technology	Absolute safety through 100% RO & UV technology.
Purifying stages	08 STAGES
Membrane type	Thin film composite Reverse Osmosis membrane.
Material of construction for plastic components	Food grade
Power rating (maximum)	65 W
Input voltage	230 V, 50 Hz
TDS reduction**	90%
System disinfection efficacy	6,4,3 log reduction of bacteria , viruses & cysts @ 30 L/h
Installation type	Floor as well as wall mounting

RECOMMENDED FEED WATER QUALITY

PARAMETERS	LIMITS
Total Dissolved solids	Up to 2000 mg/L (ppm)
Total Hardness	Up to 600 mg/L (ppm)
Turbidity ***	Up to 5 NTU
Feed water Pressure ****	0.04 MPa (6 psi) - 0.207 MPa (30 psi)
Feed water temperature	5 °C - 45 °C
Iron *****	Less than 0.3 mg/L
Free chlorine	Less than 0.2 mg/L

*Flow Rate may vary depending upon feed water quality, input water pressure, condition of membrane & cartridges

**TDS percentage reduction may vary depending upon type of feed water, feed water pressure & cartridges life

***In case, input turbidity is more than 5 NTU, you need to install pre filter at an additional cost.

****In case, input water pressure goes below 0.04 MPa (6 psi), you need to install external booster pump and if pressure is above .21 MPa (30 psi), you need to install pressure reducing valve at an additional cost

*****In case, the Iron content in input water is more than 0.3 mg/L (ppm), you need to install IRON X at an additional cost.

STAGES OF PURIFICATION 25 LPH

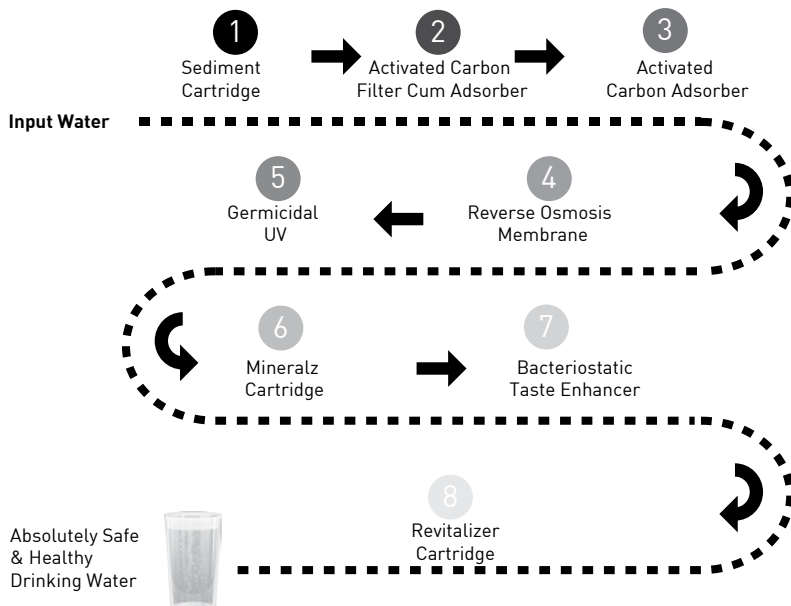
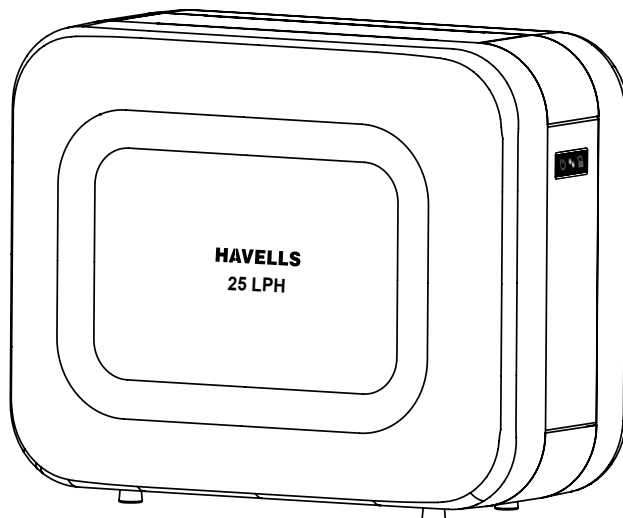

WATER FLOW DIAGRAM Model-25 LPH

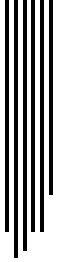
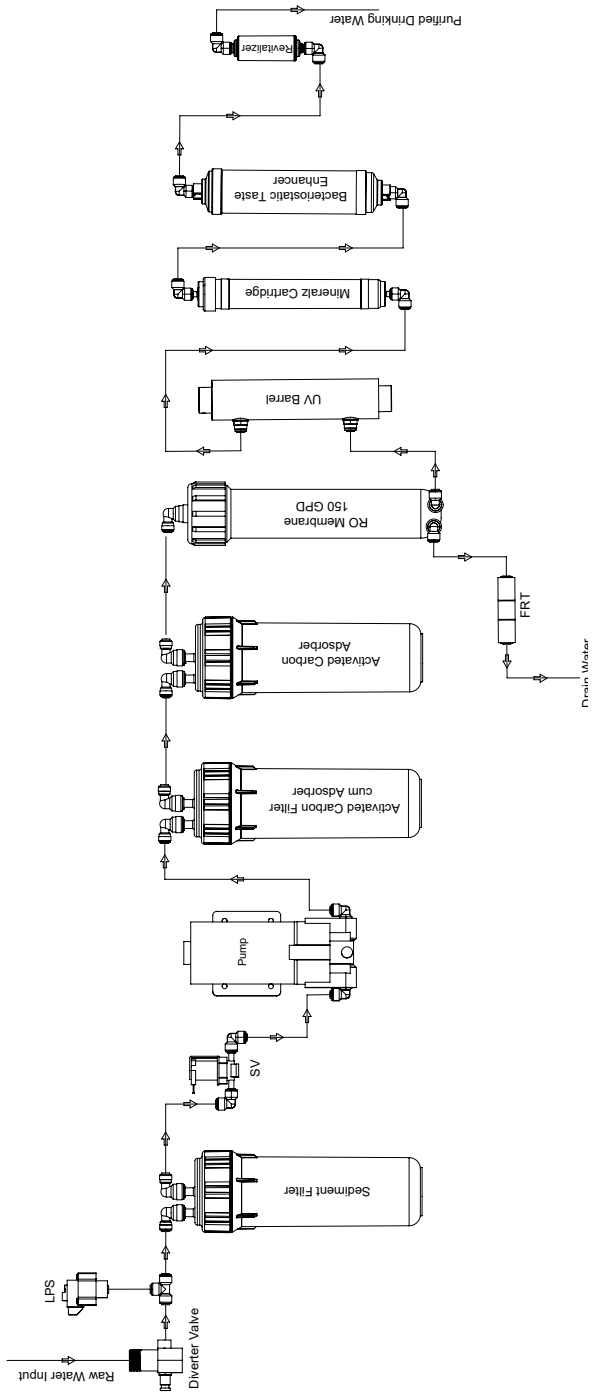

THE PURIFICATION PROCESS

Havells Water Purifiers have a powerful purification process which is divided in to 3 Phases viz. Pre-Treatment, Purification & Value Additions.

In pre- treatment process water will pass through Sediment filter, Activated Carbon filter - cum – adsorber and Activated Carbon adsorber.

During the purification process 100% water passes through RO Membrane followed by Germicidal UV disinfection column. In the final stage of purification, pH of water will be balanced and minerals will be added to purified water. Bacteriostatic Taste Enhancer will improve the taste of purified water further.

Water will pass through a controlled bipolar magnetic field which realigns the water molecules and makes it easy to absorb and more bioavailable.

The names of all the cartridges along with their functions and benefits are explained below for better understanding.

1 SEDIMENT FILTER

Sediment Cartridge removes coarse and fine suspended impurities such as sand, silt, dust, clay, rust particles etc. from the feed water. This improves the performance and the life of activated carbon cartridge and the RO membrane.



2 ACTIVATED CARBON FILTER CUM ADSORBER

Activated Carbon, filter-cum-adsorber Cartridge removes a wide range of dissolved organic impurities like pesticides and herbicides along with residual chlorine and its by-products (THMs) present in the water. It also removes colour & objectionable odour from water. This in turn improves the taste of the water.



3 ACTIVATED CARBON ADSORBER

Activated Granular carbon cartridge is made up of organic materials with high carbon contents. It is commonly used to adsorb natural organic compounds, taste and odour compounds, and synthetic organic chemicals in drinking water treatment. Its primary objective is to remove small organics and disinfection by-products and organic constituents and improves taste and minimizes health hazards.



4 REVERSE OSMOSIS MEMBRANE

Reverse Osmosis Membrane removes dissolved contaminants such as dissolved solids, salinity, pesticides, herbicides as well as hazardous heavy metals like Arsenic, Chromium, Lead and Fluorides etc. It also removes harmful microbiological impurities such as bacteria, viruses and cysts from the feed water. It ensures absolutely safe and pure drinking water.



5 GERMICIDAL UV PLUS

An optimum exposure of water to germicidal UV-C radiation in UV disinfection column makes water free from microbiological threats like pathogenic bacteria & viruses.

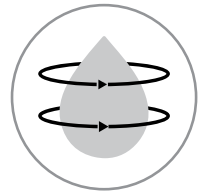

6 MINERALZ CARTRIDGE

Mineralz Cartridge balance the pH of purified water, adds back wide spectrum of natural minerals and trace elements. It delivers healthier and tastier water always.

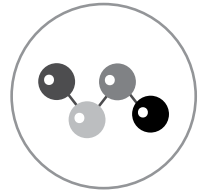

7 BACTERIOSTATIC TASTE ENHANCER

Zinc Impregnated Taste Enhancer removes organic residues and VOC. It enhances the taste of purified water and gives it a sparkling texture.



8 REVITALIZER CARTRIDGE

Revitalizer Cartridge realigns the water molecules and makes it biologically active. It improves the hydration and mineral absorption in body

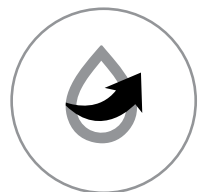

KEY FEATURES OF HAVELLS WATER PURIFIER

A. ABSOLUTE SAFETY THROUGH 100% RO & UV PURIFICATION

During Purification Stage 100% water passes through RO Membrane followed by Germicidal UV column removing a wide range of chemicals and microbiological impurities. It ensures absolutely safe and pure drinking water.



B. MINERALZ CARTRIDGE

It balances the pH of the water by adding wide spectrum of naturally occurring essential minerals and trace elements to deliver healthy and tasty water.

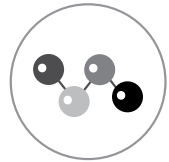

C. REVITALIZER CARTRIDGE

It realigns the water molecules and makes it biologically active. It improves the hydration and mineral absorption in body



D. CONTEMPORARY DESIGN & AESTHETICS

Futuristic design, superior dual tone colour finish, compact design and functional display panel.

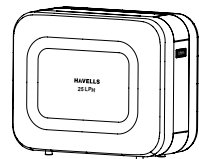

E. TDS REMOVAL OF UP TO 2000 mg/L (ppm)

Havells Water Purifiers work effectively in TDS of 2000 mg/L (ppm) and deliver pure and healthy water that taste good.



FUNCTIONS OF SMART INDICATORS



FUNCTIONAL DISPLAY INDICATORS

SELF-DIAGNOSTIC MODE

When machine is switched - ON all the indicators will glow for a fraction of second. Thereafter the power indicator will glow solid & same time purification process indicator will also glow solid for 30 second. During this period the water present in UV column will get disinfected. After 30 second the purification process will start & purification process indicator will blink till the tank is full.



PURIFICATION PROCESS INDICATOR:

Purification process indicator blinks continuously when the purification is on. It will disappear once purification process stops.



TANK FULL INDICATOR:

Tank Full Indicator glows solid when the tank is full.

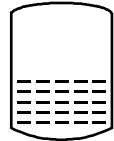

ERROR INDICATIONS:

In the event of failure of Pump and SV power indicator will start blinking @1 second with buzzer sound.
If UV intensity is less than adequate for disinfection of water power indicator will start blinking @2 second with buzzer sound.
System will shut off in both the cases to deliver you the promise of safe water or no water.
In case of low pressure condition(Input water pressure is not adequate) then only tank indication will blink.



INSTALLATION INSTRUCTIONS

1. Before installation, take out the following items from accessory kit for installation:
 - a) Diverter valve
 - b) PL 4 pipe white and blue
 - c) Wall mounting bracket
 - d) Float sensor
 - e) Float mounting bracket
2. Select an appropriate water connection point. Be sure to turn off the water supply.
3. Ensure water purifier is connected to ambient temperature water supply only.
4. Fix diverter valve with the help of pipe wrench/plumbing equipment at selected water point.
5. Place the water purifier on floor, under your counter.

OR

For wall mounting: - Align the mounting brackets at appropriate height and fix it with the help of mounting screws. Place the water purifier on mounting brackets*.

6. Install the float sensor with the cooler tank and connect the RO water pipe with the unit tank.
7. With having appropriate length of white pipe connect the water inlet pipe from diverter valve to feed water inlet port of water purifier and open the diverter valve. Ensure there is no leakage of water and kinking of pipe at any point.
8. Insert the outlet (blue pipe) to the flushed water outlet port of water purifier.
9. Plug the 3 pin power cord into the power socket.
10. Switch On the mains and unit will start working.
11. It is advised to drain approx 6 litre off water after installation of the water purifier or after changing the filters. This water can be used for washing, cleaning and other household purpose.

CAUTION:CAUTION: Before installation/mounting:-Flush all filters thoroughly and independently for 3 minutes - 5 minutes to remove fine particles present in filters.

Check input water pressure. Use booster pump if feed water pressure is less than 0.04MPa (6 psi) if it is more than 0.21 MPa (30 psi) use the PRV (Pressure reducing valve). If the input water iron content is more than 0.3 mg/L (ppm), use of iron remover is recommended as a pre-treatment. If input water turbidity is more than 5 NTU, use of Pre filter is suggested.

The appliance is intended to be permanently connected to the water mains and not connected by a hose-set.

DO'S, DON'TS & SAFETY INSTRUCTIONS

DO'S ✓

Always install the water purifier in a cool, dry and well ventilated place in upright position.

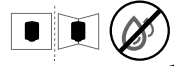

To keep your purifier functioning properly, always use Havells genuine spare parts.



Call Havells customer care for any assistance and service requirement.



Keep the purifier in power ON mode to ensure water availability at all times. System automatically shuts OFF when tank is full of purified water.



If for any reason you are not using the water purifier for a long time, for example during a holiday, then make sure that you disconnect the power supply, turn off the input water supply and drain the storage tank.



DON'TS ✘

Never connect your water purifier to hot water supply as it is designed to work effectively for input water supply between 5 °C to 45 °C temperature.



Never place any heavy, sharp or wet objects on the purifier.



In case of any break down do not buy local spareparts and components for service or replacement.



Do not install product in direct sunlight.



SAFETY INSTRUCTIONS

Havells Water Purifier is designed keeping in mind the highest safety standards, but there are certain safety precautions that need to be followed while using the product for its proper functioning.

Do not move or relocate the purifier when it is working.



To avoid electric shock, do not pull out or touch the power plug with wet hands.

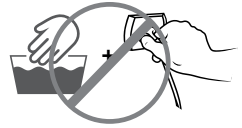

Do not use the water purifier if the power cord is damaged or if there's a strange noise, burning smell or smoke. Quickly switch off the power, unplug the cord and call Havells Customer Care.



Don't open the purifier yourself to clean the cartridges or to replace any parts.



Never use the discarded water from the purifier for drinking. However it can be used for cleaning, washing, mopping, gardening etc.

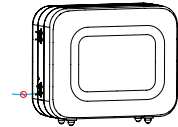

This appliance is not intended for use by persons (including children) with reduced physical, sensory or mental capabilities, or lack of experience and knowledge, unless they have been given supervision or instruction concerning use of the appliance by a person responsible for their safety.

Children should be supervised to ensure that they do not play with the appliance.

If the supply cord is damaged, it must be replaced by the manufacturer, its service agent or similarly qualified persons in order to avoid a hazard.

CLEANING AND MAINTENANCE

Use a wet cloth to clean the external body of the purifier. Do not use detergent or soap.



Avoid excessive rubbing of the decorative part of the purifier while cleaning as it may lead to scratches or loss of shine of the purifier.



Make sure you switch off the power supply and close the diverter valve whenever you're out of home for a long duration.



Do not try to open or tamper the purifier yourself if you observe any problem. Kindly contact Havells Customer Care to resolve the issue. Water purifier should be examined by Havells trained service engineer only.



Do not clean the water purifier or spill water on it, while the purification process is on.



IMPORTANT INSTRUCTIONS

Recommended Cartridge Replacement:

Sediment filter, Activated carbon filter cum adsorber, Activated Carbon adsorber & Bacteriostatic Taste Enhancer need to be replaced after 1 year of installation or dispensing 12000 litre* of purified water , which ever is earlier.



RO (Reverse Osmosis) Membrane Replacement:

As per the warranty, RO Membrane needs to be replaced after 1 year of installation or dispensing 12000 litre* of purified water, whichever is earlier.



Mineralz Cartridge Replacement:

Mineralz Cartridge needs to be replaced after 6 month of installation or after dispensing of 6000 litre*, of purified water, whichever is earlier.



Germicidal UV Column:

UV lamp needs to be replaced after 5000 burning hours or based on service requirement.



Note: Please read the warranty details and their terms and conditions for replacement requirement of individual cartridges.

* May vary depending on the feed water quality.

HOW TO REUSE THE FLUSHED WATER

Although the flushed water from the purifier has slightly higher concentration of TDS and hardness, but it is filtered and activated carbon treated tap water. It is recommended to use this water for following activities:

- Can be used for watering the plants
- Can be used for mopping and cleaning the floor
- Can be used to clean bathroom



TROUBLESHOOTING

	PROBLEMS	CHECKS	SOLUTIONS
<p>Before calling customer care or service engineer, check the following points:</p> <ol style="list-style-type: none"> 1. Power supply should be ON 2. Inlet water supply should have sufficient pressure/ Waterflow 	<p>Purified Water taste is bad or unusual</p>	<ol style="list-style-type: none"> 1. Is the tank clean? 2. Is purified water being stored in the tank for a long time? 3. Is the Cartridge replacement due as per the service requirement? 	<ol style="list-style-type: none"> 1. Clean the storage tank. 2. Discard the water stored in tank and clean the tank before starting the purification process again. 3. Contact Havells Customer Care to request for the cartridge replacement.
	<p>Purification time is very long/short or filtration has stopped/too much water is being purified.</p>	<ol style="list-style-type: none"> 1. Is the diverter valve open properly? 2. Is water pressure below recommended value? 3. One or more Cartridges may have been clogged or damaged. 	<ol style="list-style-type: none"> 1. Open the water inlet valve completely. 2. Contact Havells Customer Care to get the pressure checked and get it resolved. 3. Contact Havells Customer Care to get the cartridges replaced.
	<p>Very less or no water is being flushed out.</p>	<ol style="list-style-type: none"> 1. Check if the flushed water pipe (Blue pipe) is bent anywhere. 2. Check if the flushed water pipe is blocked in any place. 	<ol style="list-style-type: none"> 1. Remove the bend in the flush water pipe if found. 2. Switch off the purifier and contact Havells Customer Care for proper checking the product.
	<p>Water leakage in any part.</p>	<p>Check if water is dripping from purifier or connecting pipe.</p>	<p>Close the water inlet valve, unplug the power cord and then contact Havells Customer Care for a check-up of the product and get it rectified.</p>

FAQs

1. What is TDS?

TDS stands for Total Dissolved Solids in water. This affects taste of water and beverages prepared with such water.
2. Is the purification process completely automated or a manual intervention is required?

The purification process is completely automatic. Purification starts when water level in purified water tank goes down and stops once water tank is full.
3. How much time does it take to purify water in Havells Water purifier?

Havells Water Purifier (Model-25 LPH) can purify upto 25 litre of water per hour. However time taken for purification depends on the water quality, input pressure and life of the cartridges.
4. How will I get service or spare parts for my water purifier?

During the first year of usage, your product is fully covered under the warranty and service will be on demand. Please contact Havells Customer Care for service visit to your place.

Post warranty period, you can opt for either of the following two service contracts available:

 1. APMC (Annual Comprehensive maintenance contract):

Under this contract all electrical parts & service visit charges will be covered and all the filters will be covered with the below mentioned condition

What covered: All electrical parts like Internal pump, PCB, UV lamp, Wiring harness,
Two times replacement of sediment filter & mineral filter and one time replacement of all the filters, RO membrane, two preventive maintenance visits.

What not covered: Plastic parts
 2. AMCI (Annual maintenance contract) with filters:

Under this contract all the consumables like filters will be covered except RO membrane

What Covered: Two time replacement of sediment cartridge & mineral cartridge, one time replacement of cartridge except RO membrane, two preventive maintenance visit

What not covered: RO membrane and electrical & plastic parts
5. Is the water from first purification cycle fit to drink?

No, it is not recommended to either store or drink the first fill water in the storage tank. Always discard the water from the first purification cycle that gets collected in the storage tank.
6. What should I do if there is no water in the storage tank?

In case there is no water in the storage tank, please check if inlet water supply is on and power is switched on. If none of this applicable, contact Havells Customer Care for further assistance.
7. Can I service the purifier on my own?

It is not recommended. Your water purifier should always be serviced by Havells Service Engineer. Always contact the customer care if you are facing any issue which requires service or opening of the device to check it.
8. What should I do if there is a leakage from the purifier?

First switch off the purifier from power switch and then turn off the diverter valve.

Look for any visual improper fitment and contact Havells Customer Care for rectification.
9. How long the purified water stored in the storage tank can be used for drinking?

You can safely consume the purified water stored in the storage tank of your purifier for up to 2 days post purification. Just make sure that you store it away from direct sunlight. If the water is stored for more than 2 days due to any reason, then discard the complete water from the storage tank, refill the storage tank with purified water and consume it.
10. What should I do if any part of the purifier is broken?

In case any part is damaged on opening the packaging, please call the Havells Customer Care immediately. Our trained service engineer will visit your home at the earliest and assist you.
11. Are Ultraviolet light harmful like radiations?

Radiation does not cross solid objects, like metal, plastic, hence UV radiation will never come out of UV disinfection column and harm anyone.
12. Is external pre-filter part of Purifier Unit, does it come with the product purchase as part of initial packaging? Is it free?

No, Havells Water Purifier does not come with external pre-filter. A pre-filter can be installed post water quality check of input water or on customer's demand. External pre-filter is available at an additional cost.

WARRANTY TERMS AND CONDITIONS

Havells India Ltd (HIL) offers limited warranty for this water purifier against defect arising from faulty design, workmanship and material subject to the following terms and conditions:

1. All electric and functional parts are covered under warranty for 1 year from the date of purchase.
2. Consumables including sediment filter, Activated carbon filter cum adsorber, activated carbon adsorber, RO membrane, Bacteriostatic Taste Enhancer & mineralz cartridge are not covered under warranty.
3. All consumables and pump carry Havells branded embedded foil (as per Recommendation & important instruction mentioned in content no.9)
4. Havells India Limited will offer two preventive maintenance checkups during this one year term of warranty. Only Havells India Limited authorized service personnel will carry out repairs under warranty.
5. Consumers shall promptly notify the company about any defect noticed and give the company or authorized personnel/representative adequate opportunity to inspect, test and rectify the defect.
6. The company or its representatives are entitled to retain the damaged or defective parts replaced under warranty on free charge basis.
7. The company's liability under warranty will be limited only to the concerned product and its defect, which occur under conditions of normal operations in home application, under proper usage and maintenance. It excludes any defect caused due to faulty care, maintenance, repair and alteration to the product or to its part by unauthorized personnel.
8. It is mandatory to provide original bill/invoice copy along with duly stamped warranty card at the time of any repair work being done by authorized representative.
9. This warranty is confined to the first purchase of the product only and is not transferable.
10. In the event of repair during the warranty period of the purifier, this warranty will thereafter continue and remain in force only for the unexpired period of the warranty.

Replacement of part would be purely at the discretion of Havells India Limited, the same part will be replaced with the part model of price equivalent at the time of purchase.

11. The consumer will have no claim under this warranty in an event of any illness, sickness, death, personal injury, property or consequential damages arising either directly or indirectly due to utilization of product. (Authorised Service Personnel will carry out repair under warranty)
12. Warranty is not applicable and will be void under the following heads/ circumstances:
 - a. If the warranty card presented to authorized service personnel at the time of service of the product is not duly filled and stamped by the dealer.
 - b. If the product is not operated or handled as per instruction given in the operating instruction booklet.
 - c. If the device is not installed in proper procedure specified.
 - d. If any defect caused due to improper electric circuit outside the device in the house or any defective electric supply.
 - e. If installation and any repair work is carried out by an unauthorized personnel and usage of consumables and parts by unauthorized personnel. (only Havells India Limited Authorised Service Personnel will carry out repair under warranty)
 - f. If any damage caused due to transportation or shifting post installation from consumer's home.
 - g. If 12 months have expired from the date of purchase even though the device is not in use for anytime during warranty period for any reason.
 - h. If the damage is caused by pest infestation.
 - i. If product/item is not installed by company technician/ Authorised Personnel

- 
- j. If Havells water purifier is used for any purpose other than for home application purpose (not to be used for commercial purposes)
 - k. If damage to the product is caused by accidents, pests and vermin, lightning, wind, fire, floods, or acts of God
 - l. If any additional accessories were provided on the time of installation/service, the same will not be covered under standard product warranty.
 - m. If any external accessories supplied by the dealer.
13. Warranty does not cover visitation charges of service technician if this water purifier is installed beyond municipal limits of the city in which company's Authorized Service Center is situated/located. All expenses incurred in collecting the units or parts thereof from the company's authorized service center as well as expenses incurred from deputizing service personnel/technicians for conveyance and other incidentals, etc., shall be borne by the customer. Local charges for transportation and handling charges may vary by location. Customers are advised to verify in advance the aforementioned charges. If the customer wishes to bring the unit on his/her own to an authorized service center, such shall be at his/her own risks & consequences.
 14. Reinstallation or uninstallation of product based on customer demand and packing material, if used, will be chargeable.
 15. Warranty will not cover transportation cost in case customer is moving the product to another location.
 16. In case of any unpredicted situation and non -availability of spares, prevailing depreciation policy of Havells India Limited (subject to the sole discretion of Havells India Limited, may be changed without prior notice) will be applied to the product as a solution.
 17. Settlement of all claims and disputes arising out of and in relation to this water purifier shall be subject to Delhi jurisdiction only.
 18. Warranty does not cover defects arising due to causes beyond control like lightening, abnormal voltage, acts of god.
 19. The company or its Authorized Service Center reserves the right to retain any part or component replaced at its discretion in case of a defect discovered in the equipment during the warranty period.
 20. The warranty is valid within India only.



We are an environment conscious company and have started an initiative to dispose the product wastes like replaced parts and filters in an environment friendly manner. You are advised to handover the replaced parts and discarded filters to our service engineers and we will ensure that these parts are disposed of without causing any harm to the environment.

Diagrams or figures in this document are for illustration purposes only.

Copyright Subsists, Imitation of trade dress, graphics and color scheme of this document is a punishable offence.

Actual products may vary in colour, design, description and colour combination etc. Although every effort has been made to ensure accuracy in the compilation of the technical detail within this publication. Specifications & performance data are constantly changing.

090524/V1

**WARRANTY CARD
HAVELLS WATER PURIFIER**

Customer Name _____

Customer Address _____

Customer Phone Number _____

Pin Code _____

Date of Purchase _____

Dealer's Name & Address
Phone Number

Dealer's Stamp:

Product Model _____

Product Serial No. _____

* This warranty card is valid only for products sold by Havells India Limited in Indian market.
This warranty is not transferable and is applicable to the original purchaser only.



Fill out this record and keep it together with your purchase docket in a safe place. Should you require service under the terms of this warranty, please contact us.

Havells India Ltd.

QRG Tower, 2D, Sector-126, Expressway, Noida - 201304. U.P. (INDIA)

E-mail: customercare@havells.com, Website: www.havells.com

Customer Care No.: 08045 77 1313. WhatsApp No.: +91-9711773333

Join us on Facebook at www.facebook.com/havells & share your ways to save the planet!



Havells India Ltd.

QRG Tower, 2D, Sector-126, Expressway, Noida - 201304. U.P. (INDIA)

E-mail: customercare@havells.com, Website: www.havells.com

Customer Care No.: 08045 77 1313, WhatsApp No.: +91-9711773333

Join us on Facebook at www.facebook.com/havells & share your ways to save the planet!